

THE Radio Constructor

RADIO
TELEVISION
AUDIO
ELECTRONICS

VOLUME 17 NUMBER 5
A DATA PUBLICATION
PRICE TWO SHILLINGS

December 1963

COMPACT
Constructor's
TUNER

For use with a
Tape Recorder or Amplifier

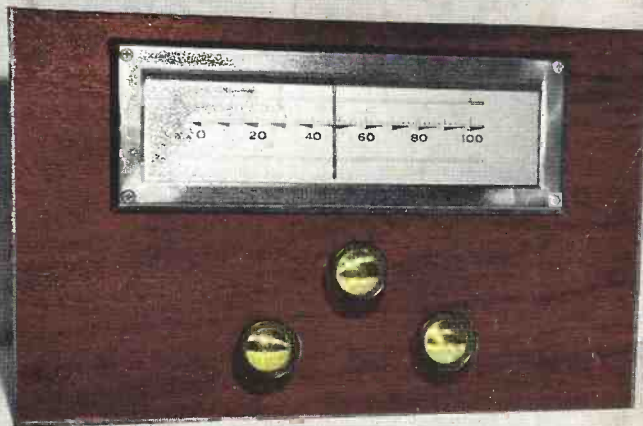

3+1 T.R.F.
Receiver

Electronic
Rev. Counter

2W -9V Transistor
Amplifier

COMPREHENSIVE TECHNICAL HANDBOOK SERVICE

**For complete data on Mullard Valves
Tubes, Semiconductors and Components**

The Mullard Technical Handbook is a loose-leaf publication, issued on a subscription basis and containing data sheets on Mullard valves, tubes, semi-conductor devices and components in current production. From one to twenty pages are devoted to each valve, tube or semiconductor type; data including the standard ratings and performance figures for various applications. Subscribers automatically receive revised sheets and supplementary data on new types, as they are introduced.

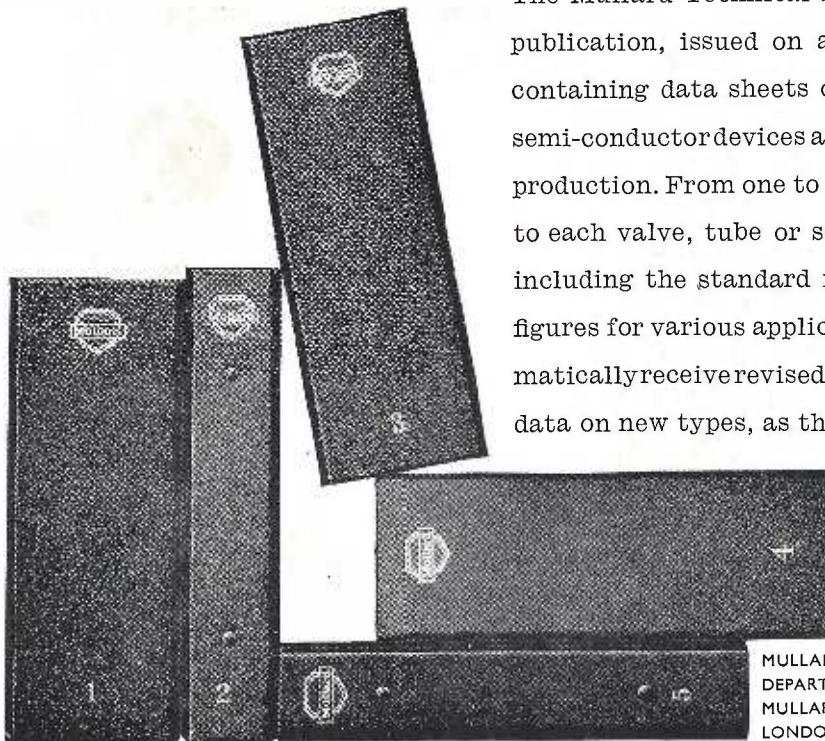

Please write for details to:

Mullard

MULLARD LIMITED
DEPARTMENT C
MULLARD HOUSE, TORRINGTON PLACE
LONDON, W.C.1. MVM 1913

LASKY'S RADIO

THE FINEST RANGE OF TRANSISTOR RECEIVERS

We consider our construction parcels to be the finest value on the home constructor market. If on receipt you feel not competent to build the set, you may return it as received within 7 days, when the sum paid will be refunded, less postage.

LASKY'S FIRST AGAIN!

NOW OFFER TO THE HOME CONSTRUCTOR, FULL SHORT WAVE COVERAGE
THE SKYROVER AND THE "SKYROVER" DE LUXE

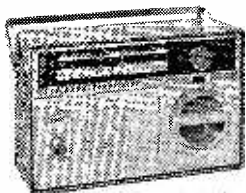

Can be built for

£10.19.6 P. and P. 5/- extra

THE SKYROVER. Controls: Waveband selector, Volume Control with on/off switch, Tuning Control. In plastic cabinet, size: 10" x 6 1/2" x 3 1/2", with metal trim and carrying handle.

GENERAL SPECIFICATION. 7 transistor plus 2 diode superhet, 6 waveband portable receiver. Operating from four 1.5 torch batteries. The SKYROVER and SKYROVER DE LUXE cover the full medium waveband, and short waveband 31-94 M, and also 4 separate switched band-spread ranges, 13M, 16M, 19M and 25M, with Band Spread Tuning for accurate Station Selection. The coil pack and tuning heart is completely factory assembled, wired and tested. The remaining assembly can be completed in under three hours from our easy to follow, stage by stage instructions.

SPECIFICATION: Superhet, 470 kc/s. All Mullard Transistors and diode. Uses 4-U2 batteries. 5" Ceramic Magnet P.M. Speaker. Easy to read Dial Scale. Band Spread Tuning. 500mW Output. Telescopic Aerial and Ferrite Rod Aerial.

WAVEBAND COVERAGE. 180-576M, 31-94M, and Band Spread on 13, 16, 19 and 25 metre Bands.

All Components Available Separately. Data for each receiver, 2/6 extra. Refunded if you purchase the parcel. Four U2 batteries, 2/8d. extra. Four Leak-proof batteries, 3/4d. extra.

THE SKYROVER DE LUXE. Tone Control Circuit is incorporated, with separate Tone Control in addition to Volume Control, Tuning Control and Waveband Selector. In a wood cabinet, size 11 1/2" x 6 1/2" x 3 1/2" covered with a washable material, with plastic trim and carrying handle. Also car aerial socket fitted.



Can be built for

£12.19.6

P. and P. 5/- extra

THE SPRITE

CAN BE BUILT FOR **79/6**
P. and P. 3/6 extra



- ★ Six-Transistor Superhet Miniature Personal Pocket Radio
- ★ Long and medium wavebands
- ★ Ferrite Rod Aerial
- ★ I.F. Frequency 470 kc/s
- ★ 3" speaker

- ★ Printed circuit 2 1/2" x 2"
- ★ Slow Motion Drive
- ★ In Plastic Case. Size 4" x 2 1/2" x 2".

In order to ensure perfect results, the SPRITE is supplied to you with R.F. and L.F. stages. Driver and Output stages ready built with all components mounted on the printed circuit. The SPRITE pre-assembled, plus cabinet, speaker and all components for final construction, can be built for 79/6. Postage and package 3/6 extra. Data and instructions separately 2/6. Refunded if parcel is purchased. Real calf leather case, wrist-strap, personal earphone and case for earphone and battery, 12/6 the lot extra. Make no mistake this is a SUPERHET receiver of genuine commercial quality. It is not a regenerative circuit.

TRANSFILTERS by BRUSH CRYSTAL CO.

TO-01B 465 kc/s ± 2 kc/s
TO-01D 470 kc/s ± 2 kc/s
TO-02B 465 kc/s ± 1 kc/s
TO-02D 470 kc/s ± 1 kc/s

6/6 each
P. & P. 6d.

TRANSISTORS

All New and Guaranteed
GET.51, GET.55, GET.56—2/6; 837A, 874P—3/6; OC.45, OC.71, OC.81D—4/6; OC.44, OC.70, OC.76, OC.81 (Matched pair 10/6)—8/6; AF.117, OC.72, OC.75, OC.170, OC.171, OC.200—6/6; OC.25, OC.42, OC.43, OC.73, OC.82D—7/6; OCP.71—9/6; OC.28, OC.201, OC.204—15/-; OC.205, OC.206—19/6.

ELECTRIC MOTORS



Brand new tape recorder motors. Single phase, fully shrouded, 200-250V A.C. 3/4" x 1/2" spindle with detachable pulley, fitted switch. Suitable for tape decks, record players and many other uses. **14/11**
P. & P. 3/6.

IDEAL PRESENTS

BOY'S TRANSISTOR RADIO. Ready built, 2-transistor pocket radio. In attractive plastic case. Size only 4" x 2 1/2" x 1". Fitted with 2 1/2" loudspeaker. Socket for personal earpiece and telescopic aerial. Works from single PP3-type battery. Fully tunable over full Medium waveband. Supplied complete with earpiece, telescopic aerial, carrying purse and 9 volt battery. Ideal Birthday or Christmas Present.

LASKY'S PRICE 42/-

with all accessories. P. & P. 2/6

6-Transistor Pocket Radio. Fully built. 4" x 2 1/2" x 1", with 2 1/2" speaker. Uses single PP3-type battery. Supplied complete with personal earpiece and leather case. Tunable over full Medium waveband. **LASKY'S PRICE 79/6** complete with all accessories. P. & P. 2/6.

LASKY'S CAR RADIO

Can now be built absolutely complete for **£9.19.6**



- ★ Small size. Will fit any car
- ★ 12 volt operation
- ★ New Hybrid circuit
- ★ Transistor output
- ★ New type Brimar valves
- ★ No Vibrator, 12 volt H.T. & L.T.
- ★ T.C.C. Printed Circuit and Condensers
- ★ Tuned R.F. stage
- ★ Medium and long waves
- ★ Permeability tuning
- ★ 7" x 4" elliptical speaker

Instruction Booklet giving full details, illustrations, dimensions, circuit diagram and shopping list, 2/6 post free (returned if you order).

REALISTIC 'SEVEN'

- ★ 7 Transistor Superhet
- ★ 350 Milliwatt output into 4" high flux speaker
- ★ All components mounted on a single printed circuit board, size 5 1/2" x 5 1/2" in one complete assembly
- ★ Plastic cabinet, with carrying handle, size 7" x 10" x 3 1/2" in Blue/Grey.
- ★ Easy to read Dial
- ★ External Socket for car aerial
- ★ I.F. frequency 470 kc/s
- ★ Ferrite rod internal aerial
- ★ Operates from PP9 or similar battery
- ★ Full comprehensive data supplied with each receiver
- ★ All coils and I.F.s, etc., fully wound ready for immediate assembly



An outstanding Receiver. The Realistic '7' including Transistors, Cabinet, Speaker, etc., and full instructional Data can be built for

£5.19.6 P. & P. 4/6

PP9 Batt. 3/9. Data and instructions separately 2/6. Refunded if you purchase the parcel.

REALISTIC 'Seven' De Luxe

By popular request a De Luxe version of the well-proven 'Realistic Seven' now available. With the same electrical specification as standard model PLUS A SUPERIOR WOOD CABINET IN CONTEMPORARY STYLING, covered in attractive washable material, with superchrome trim and carrying handle. Also a full vision circular dial, externally mounted to further enhance the pleasant styling. ALL FOR ONLY £1 EXTRA. P. & P. as for Standard model.

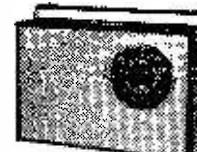

DISTLER MINIATURE MOTORS
6 volt battery operated. P. & P. 2/6 **7/11**

33 TOTENHAM COURT ROAD · W1

2 mins. Oxford St. Nearest Station: Goudge St.

MUSEum 2605

Tottenham Ct. Rd. & Edgware Rd. addresses open all day Sat. Close 1 Thur.

207 EDGWARE ROAD · W2

Few yards from Praed St.

PADdington 3271/2

Please address all Mail Orders to Dept. W at above Edgware Road address

152/3 FLEET STREET · EC4

(ELECTRONICS · Fleet St. Ltd.) FLEet 2833

Open all day Thurs. Closed 1 p.m. Sat.

NOW! ANOTHER PURCHASE of the year's keenest TAPE RECORDER BARGAIN!



A 24 gns. Tape Recorder offered at the bargain price of only 15 gns. plus 10/- Carr. Supplied in 3 Units already wired and tested. A modern Circuit for quality recording from Mike, Gram or Radio, using latest B.S.R. Twin Track Monardeck Type TD2. Magic Eye recording Indicator, Ext. spkr., switch, super-impose and straight-through amplifier facilities, etc.

Valve line-up—EF86, ECL82, EM84, EZ80 and Silicon Diode.

2 tone Cabinet and 8" x 5" Speaker. Size 14" x 10 1/2" x 7 1/2" **£3.10.0** + 5/- carr.

Wired Amplifier complete with 4 valves, Front Panel, Knobs **£5.12.6** + 3/6 carr.

B.S.R. Monardeck Type T.D.2 **£7. 7.0** + 4/6 carr.

Accessories—Mike, Spare Reel Tape, Screened Lead, Plugs, etc. **£1. 1.0** + 2/- carr.

COMPLETE KIT comprising items above **15 gns.** + 10/- carr.

Leaflet, Circuit and Instruction 2/- post free

New Boxed VALVES	Reduced Bargain Prices	Electrolytics	All Tubular	Types New Stk. CAN TYPES					
1T4	3/6	ECC83	7/10	PCC84	8/10	50/12V	1/9	8-8/450V	4/6
1R5	6/-	ECL82	10/-	PCF80	8/10	50/50V	2/-	16+16/450V	5/6
1S5	6/-	ECL80	9/10	PCL83	10/6	100/25V	2/-	32+32/275V	4/6
3S4	7/-	EF80	7/6	PCL84	10/-	8/450V	2/3	50-50/350V	6/6
3V4	7/-	EF86	8/6	PL81	9/6	4/350V	2/3	60+250/	
DAF96	8/-	EL84	7/-	PL82	9/6	16+16/450V	5/6	275V	12/6
DF96	8/-	EY51	9/-	PL83	8/6	32+32/450V	6/6	100+300/	
DK96	8/-	EY86	9/-	PY32	7/6	1000/25V	3/9	275V	12/6
DL96	8/-	EZ81	7/-	PY81	8/10			6V	3/6
ECC81	7/-	GZ32	9/6	PY82	7/-			6V	3/6
ECC82	7/-	EM84	8/6	U25	10/6			6V	3/6

Ersin Multicore Solder 60/40 4d. per yard. Cartons 2/6, etc.

NEW BRITISH RECORDING TAPE

Famous Mfr. Bulk Purchase—Genuine recommended Tape Bargain. Uncond. Guar. Fitted Leader & Stop Foils (except 3").

Standard (PVC base)	Long Play (PVC base)	D'ble Play (Mylar base)
3" 150ft. ... 3/9	225ft. ... 4/9	300ft. ... 6/6
5" 600ft. ... 11/6	900ft. ... 15/-	1,200ft. ... 25/-
5 1/2" 850ft. ... 14/6	1,200ft. ... 17/6	1,800ft. ... 32/6
7" 1,300ft. ... 17/6	2,400ft. ... 22/6	2,400ft. ... 42/6

Post and Packing—3" Reels 6d. Each additional Reel 3d. 4" to 7" Reels 1/- Each additional Reel 6d.

EMPTY TAPE REELS (Plastic): 3" 1/3; 5" 2/-, 5 1/2" 2/-, 7" 2/3, PLASTIC REEL CONTAINERS (Cassettes): 5" 1/9, 5 1/2" 2/-, 7" 2/3

Jack Plugs. Standard 2 1/2" Igranitic Type, 2/6. Screened Ditto, 3/3. Miniature scr. 1 1/2", 2/3. Sub-min. 1/3.
Jack Sockets. Open Igranitic Moulded Type, 3/6. Closed Ditto, 4/-, Miniature Closed Type, 1/6. Sub-min. (deaf aid) ditto, 1/6. Stereo Jack Sockets, 3/6. Stereo Jack Plugs, 3/6.
Phono Plugs, 9d. Phono Sockets (open), 9d. Ditto (closed), 1/-, Twin Phono Sockets (open), 1/3.
Grundig Continental. 3 p. or 5 p. plug, 3/6. Sockets, 1/6.

Soldering Irons. Mains 200/220V or 230/250V. Solen 25 watt Inst., 2/3. Spare Elements, 4/6. Bits, 1/- 65 watt, 27/6 etc.

Alumin. Chassis. 18g. Plain Undrilled, folded 4 sides, 2" deep. 6" x 4", 4", 6", 8" x 6", 5", 9", 10" x 7", 6", 9", 12" x 6", 7/6, 12" x 8", 8/- etc.

Alumin. Sheet. 18g. 6" x 6", 1/- 6" x 9", 1/6, 6" x 12", 2/-, 12" x 12", 4/6 etc.

RECORD PLAYER CABINETS

Contemporary style, rexine covered cabinet in two-tone maroon and cream. Size 15 1/2" x 14 1/2" x 8 1/2", fitted with all accessories including baffle board and Vinair fret. Space available for all modern amplifiers and auto-changers, etc. Uncond. record player mounting board 14 1/2" x 12 1/2" supplied Cabinet Price 59/6. Carr. and Ins. 5/-.

2-VALVE 2 WATT AMPLIFIER

EZ80 and Twin stage ECL82 with vol. and neg. feedback tone control. A.C. 200/250V with knobs, etc., ready wired to fit above cabinet. £2.17.6. P. & P. 1/6. 7" x 4" Speaker and trans. 22/-, P. & P. 2/-.

COMPLETE R/PLAYER KIT. As ill. inc. BSR UA14 Unit. New Bargain Price Now Only £11.10.0, 7/6 carr.



Now Available! De luxe Record Player Kit

Based on Mullard's 3-watt amplifier with printed circuit and Bass Boost and Treble Controls and 8" x 5" High Flux Speaker and Garrard Auto-Slim Unit. Cabinet size, 17 1/2" x 16" x 8". Send for full details; 3d. stamp.

Complete Kit **£13.19.6** carr. 10/-

Volume Controls—5K-2 Meg-ohms, 3" Spindles Morganite Midget Type, 1 1/2" diam. Guar. 1 year. LOG or L.H. ratios less Sw. 3/- DP. SW. 4/6. Twin Stereo less Sw. 6/6. D.P. Sw. 9/6 (100 k. to 2 Meg. only).

COAX 80 OHM CABLE

High grade low loss Cellular air spaced Polythene—1/2" diameter. Stranded cond. Famous mfrs. Now only 6d. per yard. Bargain

Prices—Special lengths:
20 yds. 9/-, P. & P. 1/6.
40 yds. 17/6, P. & P. 2/-.
60 yds. 25/-, P. & P. 3/-.
Coax Plugs 1/-, Sockets 1/-, Couplers 1/3, Outlet Boxes 4/6

Condensers—S/Mica all values 2pF to 1,000pF 6d. Ditto Ceramic 9d. each, .005, .01 and .1, etc., 1/- Paper. Tubular 450V .001 mfd to .01 mfd and 1/350V 9d. .02-1 m d 1/-, .25 mfd 1/6, .5 mfd 1/9.

Close Tol. S/Micas—10% 5pF-500pF 8d. 600-5,000pF 1/-, 1% 2pF-100pF 1/-, 100pF-500pF 11d. 575pF-5,000pF 1/6. Resistors—Full Range 10 ohms-10 megohms 20% ± and 1/2W 3d., 3W 5d. (Midget type modern rating) 1W 6d., 2W 9d. Hi-Stab 5% ± 1W 100 ohms 1 megohm 6d. Other values 9d. 15% ± W 1/6 W/W Resistors 25 ohms to 10K 5W 1/3, 10W 1/6, 15W 2/-.

Pre-set T/V Pots. W/W 25 ohms-50K 3/-, 50K-2 Meg. (Carbon) 3/-.

TRANSISTOR BARGAINS

Brand New—BVA 1st Grade

OC44	8/6	OC70	5/6
OC45	8/6	OC71	6/6
OC81D	7/6	GEX34	2/9
2/OC81	15/6	OA70	2/9
GET114	6/6	OA81	2/9
OC72	7/6	GEX13	2/9
AF117	9/6		

Speakers P.M.—3 ohms 2 1/2" E.M.I. 15/6. Goodmans 3 1/2" 16/6, 5" Rola 15/6. 6" Elac 16/6, 7" x 4" Goodmans 15/6, 8" Rola 19/6, 10" R. x A. 25/-, 9" x 6" Goodmans 22/6. E.M.I. Tweeter 22/6.

Speaker Fret—Expanded gilt anodised metal 1/2" x 1/2" diamond mesh, 4/6 sq. ft., multiples of 6" cut. Max. size, 4ft. x 3ft. 47/6. Carr. extra.
TYGAM. FRET (contemp. pat.) 12" x 12" 2/-, 12" x 18" 3/-, 12" x 24" 4/-, 18" x 18" 4/6, etc.
BONDACOUST Speaker Cabinet Acoustic Wadding, 12" wide, any length cut 1/6 per ft, 4/- per yd.

BARGAINS 4-SPEED PLAYER UNITS

Single Players carr. 3/6
E.M.I. Stereo/Mono **£5.10.0**
E.S.R. Latest Model TUI2 **72/6**
E.M.I. Junior "985" **67/6**

Auto-Changers carr. 5/-
Garrard "Auto-Slim" **£6.17.6**
B.S.R. (UA16) **£6.19.6**
B.S.R. (UA14) **£6.10.0**

7 VALVE AM/FM RADIOGRAM CHASSIS

Three Waveband & Switched Gram positions. Med. 200-550m. Long 1,000-2,000m. VHF/FM 88-95 Mc/s. Phillips Continental Tuning insert with permeability tuning on FM & combined AM/FM IF transformers. 460 kc/s and 10.7 Mc/s. Disting core tuning all coils. Latest circuitry including AVC & Neg. Feedback, 3 watt output. Sensitivity and reproduction of a very high standard. Chassis size 13 1/2" x 6 1/2" Height 7 1/2". Edge illuminated glass dial 1 1/2" x 3 1/2". Vert. pointer Horiz. station names. Gold on brown background. A.C. 200/250V operation. Magic-eye tuning. Circuit diag. now available.

Valve line-up ECC85, ECH81, EF89, EAB80, EL84, EM81, EZ80



Aligned and tested ready for **£13.10.0** Carr. & Ins. 5/- use.

Comp. with 4 knobs—walnut or ivory to choice. Indoor FM aerial 3/6 etc. 3 Ω P.M. Speaker only required. Recommended Quality Speakers 10" Elac H/D, 30/-, 13 1/2" x 8" E.M.I. Fidelity, 35/-, 12" R.A. with cone Tweeter, 42/6. Carr. 2/6.

Send for detailed bargain lists, 3d. stamp. We manufacture all types Radio Mains Transf. Chokes, Quality O/P Trans., etc. Enquiries invited for Specials, Prototypes for small production runs. Quotation by return.

RADIO COMPONENT SPECIALISTS

70 Brigstock Rd., Thornton Heath, Surrey
THO 2188 Hours: 9 a.m. - 6 p.m., 1 p.m. Wed. Terms C.W.O. or C.O.D. Post and Packing up to 1/2 lb 9d., 1 lb., 1/3 3lb., 2/3 5 lb., 2/9 8 lb. 3/6.



HI-FI AMPLIFIERS TUNERS RECORD PLAYERS

S-33



S-99



GL-58

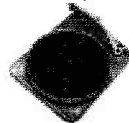

HA-12



HI-FI 6W STEREO AMPLIFIER. Model S-33. 3 watts per channel 0.3% distortion at 2.5W/chnl., 20dB N.F.B. Inputs for Radio (or Tape) and Gram, Stereo or Monaural, ganged controls. Sensitivity 200mV. **£13.7.6**

DE LUXE STEREO AMPLIFIER. Model S-33H. De luxe version of the S-33 with two-tone grey perspex panel, and higher sensitivity necessary to accept the Decca Deram pick-up. **£15.17.6**

HI-FI STEREO AMPLIFIER. Model S-99. 18W output. Ganged controls. Stereo/Mono gram., radio and tape inputs. Push-button selection. Printed circuit construction. **£27.19.6**

POWER SUPPLY UNIT. Model MGP-1. Input 100/120V, 200/250V. 40-60 c/s. Output 6.3V, 2.5A A.C. 200, 250, 270V, 120mA max. D.C. **£5.2.6**

A wide range of American Audio equipment available. See Direct Mail order scheme below.

GOLDRING LENCO TRANSCRIPTION PLAYER. Model GL-58. With G-60 pick-up arm and Ronette 105 cartridge. **£18.19.2**

GARRARD AUTO/RECORD PLAYER. Model AT-6. With R 105 cartridge. **£13.12.1** With Decca Deram pick-up **£14.6.1**

SUGDEN MOTOR UNIT "CONNOISSEUR CRAFTSMAN". Heavy duty motor operating at 33½ and 45 r.p.m. Very heavy 12" turntable. Virtually no rumble. **£16.6.6**

HI-FI MONO AMPLIFIER. Model MA-5. A general purpose 5W Amplifier, with inputs for Gram., Radio. Presentation similar to S-33. **£10.19.6**

HI-FI MONO AMPLIFIER. Model MA-12. 12W output, wide freq. range, low distortion. **£11.9.6**



Enjoy Yourself and Save Money

TEST INSTRUMENTS

5" OSCILLOSCOPE. Model O-12U. Has wide-band amplifiers, essential for TV servicing, FM alignment, etc. Vertical frequency response 3 c/s to over 5 Mc/s, without extra switching T/B covers 10 c/s to 500 kc/s in 5 ranges. **£35.10.0**

2½" SERVICE SCOPE. Model OS-1. Light, compact portable for service engineers. Dim. 5" x 8" x 14½" long. Wt. 10½ lb. **£19.19.0**

ELECTRONIC SWITCH. Model S-3U (Oscilloscope Trace Doubler). Enables a single beam oscilloscope to give simultaneous traces of two separate and independent signals. Switching rates approx. 150, 500, 1,500, 5,000 and 15,000 c/s. Sig. freq. response 0-100 kc/s. ±1dB. Separate gain controls and sync. output. Sig. input range 0.1-1.8V r.m.s. **£11.15.6**

AUDIO SIGNAL GENERATOR. Model AG-9U 10 c/s to 100 kc/s, switch selected. Distortion less than 0.1%, 10V sine wave output metered in volts and dB's. **£21.9.6**

RESISTANCE/CAPACITANCE BRIDGE. Model C-3U. Measures capacity 10pF to 1,000µF, resistance 100Ω to 5MΩ and power factor, 5-450V test voltages. With safety switch. **£9.5.0**



O-12U



S-3U



C-3U

CAPACITANCE METER. Model CM-1U. Direct-reading 4½" scale. Full-scale ranges 0-100µF, 0-1,000µF 0-0.01µF and 0-0.1µF. **£15.15.0**

VALVE VOLTMETER. Model V-7A. 7 voltage ranges d.c. volts to 1,500. A.C. to 1,500 r.m.s. and 4,000 peak to peak. Resistance 0.1Ω to 1,000MΩ with internal battery. D.C. input impedance 11MΩ. dB measurement, has centre-zero scale. Complete with test prods, lead and standardising battery. **£13.18.6**

MULTIMETER. Model MM-1U. Ranges 0-1.5V to 1,500V A.C. and D.C.; 150µA to 15A D.C.; 0.2Ω to 20MΩ. 4½" 50µA meter. **£12.10.0**

R.F. SIGNAL GENERATOR. Model RF-1U. Up to 100 Mc/s fundamental and 200 Mc/s on harmonics and up to 100mV output on all bands. **£12.15.6**

AUDIO WATTMETER. Model AW-1U. Up to 25W continuous, 50W intermittent. **£15.15.0**

AUDIO VALVE MILLIVOLTMETER. Model AV-3U. 1mV-300V f.s.d. A.C. 10 c/s to 400 kc/s. **£14.17.6**

AUDIO SINE-SQUARE WAVE GENERATOR. Model AO-1U. Covers 20 c/s to 150 kc/s and square waves to 50 kc/s in four ranges. Maximum output 10V, distortion less than 1%. **£13.15.0**



V-7A



RF-1U



SSU-1



MFS

SPEAKER SYSTEMS

HI-FI SPEAKER SYSTEM. Model SSU-1. Ducted-port bass reflex cabinet "in the white". Two speakers. Vertical or horizontal models with legs **£11.12.0** without legs **£10.17.6**

THE "COTSWOLD". This is an acoustically designed enclosure 26" x 23" x 15½" housing a 12" bass speaker with 2" speech coil, elliptical middle speaker together with a pressure unit to cover the full frequency range of 32-20,000 c/s. Capable of doing justice to the finest programme source, its polar distribution makes it ideal for really Hi-Fi Stereo.

COTSWOLD "MFS" SYSTEM. Specially developed to give best possible results in small rooms. This minimum floor space model is based on standard Cotswold. Size: 36" high x 16½" wide x 14½" deep. Either Model. **£23.4.0**

FOR THE MUSICIAN



PA-1

PA AMPLIFIER PA-1. The ideal compact unit for VOCALISTS, INSTRUMENTALISTS, RECORDS, with 50W (100W pk output), 2 Heavy Duty Speakers. Variable TREMOLO Elegant modern cabinet. Send for full specification. **£54.15.0**

Legs optional extra 17/6 set of 4.

ELECTRONIC ORGAN

(fully transistorised)

Ideal for Soloists, Home use, Groups. Full 20 WATTS VOLUME. With matching bench. **£219.0.0**

A RANGE OF

250 AMERICAN HEATHKIT MODELS

Now obtainable for direct delivery from U.S. plant to your U.K. address. Illustrated catalogue and full details of mail order scheme can be obtained from us for the nominal charge of 1/- post paid.

Money-back Guarantee

Daystrom Limited unconditionally guarantees that each Heathkit product assembled in accordance with our easy-to-understand instruction manual must meet our published specifications for performance or the purchase price will be cheerfully refunded.

TAPE DECKS CONTROL UNITS TAPE AMPLIFIERS



COLLARO



D-83



FM-4



AM/FM

COLLARO "STUDIO" TAPE DECK. The finest buy in its price range. Operating speeds: 1½", 3¼" and 7½" p.s. Two tracks "wow" and "flutter" not greater than 0.15% at 7½" p.s. **£17.10.0**

TRUVOX D83/2 & D83/4 TAPE DECKS. High quality mono/stereo tape decks.

D83/2, 2 track, £31.10.0 D83/4, 4 track, £29.8.0

HI-FI AM/FM TUNER. Model AFM-1. Available in two units which, for your convenience, are sold separately. Tuning heart (AFM-T1—£4.13.6 incl. P.T.) and I.F. amplifier (AFM-A1—£20.13.0). Printed circuit board, 8 valves. Covers L.W., M.W., S.W., and F.M. Built-in power supply. Total **£25.6.6**

HI-FI FM TUNER. Model FM-4U. Also available in two units. R.F. tuning unit (£2.15.0 incl. P.T.) with I.F. output of 10.7 Mc/s, and amplifier unit, with power supply and valves (£12.6.0). Total **£15.1.0**

TAPE RECORDING/PLAYBACK AMPLIFIER. Thermometer type recording indicators, press-button speed compensation and input selection. Mono Model TA-1M, **£19.2.6** Stereo Model TA-1S, **£24.10.0**

MONO CONTROL UNIT. Model UMC-1. Designed to work with the MA-12 or similar amplifier requiring 0.25V or less for full output. 5 inputs. Baxandall type controls. **£8.12.6**

STEREO CONTROL UNIT. Model USC-1. Push-button selection, accurately matched ganged controls to ±1dB. Negative feedback, rumble and variable low-pass filters. Printed circuit boards. **£19.10.0**

Building these Heathkit models



TRANSISTOR RADIOS

LATEST MODEL! "OXFORD" LUXURY PORTABLE. Model UXR-2. Specially designed for use as a domestic, car or personal portable receiver. Many features, including solid leather case. **£14.18.0**



UXR-2

TRANSISTOR PORTABLE. Model UXR-1. Pre-aligned I.F. transformers, printed circuit. Covers L.W. and M.W. Has 7" x 4" loudspeaker. Real hide case. **£12.11.0**



UXR-1

TRANSISTOR PORTABLE RECEIVER. Model RSW-1. In a handsome leather case, it has retractable whip aerial and socket for car radio use. Covers Med., Trawler and two S wave bands. **£19.17.6**



UJR-1

JUNIOR TRANSISTOR RADIO. Model UJR-1. Single transistor set. Excellent introduction to radio. **£2.7.6**

AMATEUR EQUIPMENT

AMATEUR BANDS RECEIVER. Model RA-1. To cover all the Amateur Bands from 160-10 metres. Many special features, including: half-lattice crystal filter; 8 valves; signal strength "S" meter; tuned R.F. Amplifier Stage. Send for spec. **£39.6.6**



RA-1

THE "MOHICAN" GENERAL COVERAGE RECEIVER. Model GC-1U. With 4 piezo-electric transmitters, variable tuned B.F.O. and Zener diode stabiliser, this is an excellent fully transistorised general purpose receiver for Amateur and Short wave listeners. Printed circuit boards, telescopic whip antenna, tuning meter and large slide-rule dial, 10 transistors. **£39.17.6**

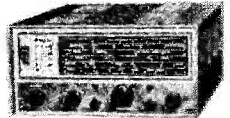

RG-1

AMATEUR TRANSMITTER. Model DX-100U. The world's most popular, compact and completely self-contained Amateur Transmitter. Covers all amateur bands: 160-10 m. 150W d.c. input. Careful design has achieved the stability and high performance for which the DX-100U is noted and no less than 35 disc ceramic capacitors reduce TVI to a minimum. **£74.19.0**

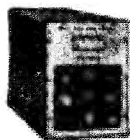

SB-10U

SINGLE SIDEBAND ADAPTOR. Model SB-10U. May be used with most A.M. transmitters. Less than 3W R.F. input power required for 10W output. Operation on 80, 40, 20, 15 and 10m bands on U.S.B., L.S.B. or D.S.B. **£39.5.0**

AMATEUR TRANSMITTER. Model DX-40U. Covers all amateur bands from 80 to 10 metres; crystal controlled. Power input 75W C.W., 60W peak controlled carrier phone. Output 40W to aerial. Provision for V.F.O. Filters minimise TV interference. **£33.19.0**



DX-40U

New Model RG-1

COMMUNICATIONS TYPE RECEIVER.

A high performance, low cost receiver for the discriminating listener. Frequency coverage: 600 kc/s-1.5 Mc/s and 1.7 Mc/s-32 Mc/s. Send for full specification. **£39.16.0**

VARIABLE FREQUENCY OSCILLATOR. Model VF-1U. Calibrated, 160-10 m. Fundamentals on 160 and 40m. Ideal for our DX-40U and similar transmitters. **£11.17.6**

HI-FI EQUIPMENT CABINETS



"GLOUCESTER"

A wide range of equipment cabinets are available to meet the differing needs of enthusiasts. Designed for max. operating convenience or for where room space is an overriding consideration this range includes kits, ready assembled cabinets or fully finished cabinets, and has at least one model to suit your requirements. Send for full details.

Other models from our wide range include

TELEPHONE AMPLIFIER TTA-1 **£7.9.6**

TRANSISTOR INTERCOM. X1R-1U (remote) **£4.7.6**

X1-1U (master) **£10.19.6**

ELECTRONIC WORKSHOP EW-1. Makes over 21 experiments. The ideal present for the youngster. **£7.13.6**

All models also available assembled
Deferred Terms over £10

Send coupon for **FREE** illustrated British catalogue of Heathkit range to:

DAYSTROM LTD DEPT. RC.12
GLOUCESTER

A wide range of American amateur equipment. See Mail Order Scheme.

Without obligation please send me **FREE BRITISH HEATHKIT CATALOGUE**..... (Tick here)

FULL DETAILS OF MODEL(S).....
(Please write in BLOCK CAPITALS)

NAME.....

ADDRESS.....

DEPT. RC.12



GO TRANSISTOR WITH SINCLAIR

BRITAIN'S LEADING TRANSISTOR SPECIALISTS

3 VITAL BOOKS FOR THE TRANSISTOR USER

Here are three books to keep you in step with the very latest developments in transistor design and practice. Each is crammed with invaluable information, tested circuits and layout diagrams. All are expertly prepared and based on Sinclair Transistors. These three books cover an exciting range of transistor applications. You can save 2/6 by buying all three together for

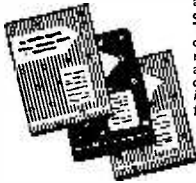

15/-
POST FREE

GENERAL

"22 Tested Circuits Using Micro Alloy Transistors." Post free **5/6**

SHORT WAVES

"Tested Short Wave Receivers Using MATs." Post Free **5/6**

S.W. & COMMUNICATIONS

"Tested Superhet Circuits for Short wave and Communication Receivers, using MATs." Post free **6/6**

THE WONDERFUL SINCLAIR RANGE OF TRANSISTORS

M.A.T.'s

(MICRO-ALLOY TRANSISTORS)

Give extremely high power gains at all levels of collector current and voltage and from A.F. to 100 Mc/s. Greatly improve performance of any circuit.

MAT 100 High gain low level.....	7/9
MAT 101 Extra high gain, low level.....	8/6
MAT 120 High gain, medium and high level.....	7/9
MAT 121 Extra high gain, medium and high level.....	8/6

ADT.140 FOR V.H.F. and U.H.F.

Only 1/5" high x 1/5" dia. Made by the unique alloy-diffused process, and specially suitable for F.M., T.V., V.H.F. and U.H.F. frequencies. Has typical alpha cut-off of 400 Mc/s with power gains of 15dB at 100 Mc/s and 9dB at 200 Mc/s. **15/-**

TWO OUTSTANDING AF AMPLIFIERS

SINCLAIR TR5

COMBINED PRE-AMP AND HALF-WATT POWER AMPLIFIER

Will produce a perfectly clean half-watt of audio power even from very low output sources such as low-impedance tape heads, pick-ups and microphones. Ready built with instructions and unconditionally guaranteed.

CIRCUIT—5 matched transistors and temperature compensating diode in a transformerless complementary-symmetry configuration.

POWER OUTPUT—500mW undistorted into 15 ohms.

SENSITIVITY—0.5mV.

POWER GAIN—30dB (100 million times).

FREQUENCY RESPONSE—50 c/s to 20

kc/s ± 3 dB.

SIZE— $2\frac{1}{2}$ " x $1\frac{1}{2}$ " x 3"

POWER REQUIREMENTS—9V battery or power supply.

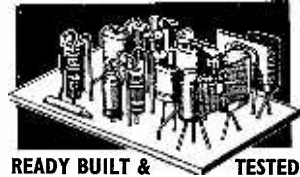

READY BUILT & TESTED

"I have tried the TR5 amplifier with a gram P.U. feed and find it a remarkable 'mighty atom' with astonishing volume & quality." D.A.B., Welwyn Garden City

"The micro-amplifier kit was received yesterday. The assembly time was about 15 minutes, and it is doing the job so well that I felt I must let you know how pleased I am with it. Please forward as soon as possible another micro-amplifier. If this letter is of any use to you in advertising, please feel free to use it. D.H., nr. Gaine, Wilts

59/6

SINCLAIR MICRO - AMPLIFIER



40 dB GAIN at 1 Mc/s

OUTPERFORMS AMPLIFIERS 20 TIMES LARGER

This fantastically powerful amplifier is smaller than a 3d. piece. With a frequency response from 30 to 50,000 c/s ± 1 dB, and power gain of 60dB

(1,000,000 times) it can be used as a sub-miniature hi-fi amplifier with an output suitable for any earpiece or even a loudspeaker.

28/6

With MAT Transistors, brand new micro-miniature quality components and micro-printed circuit. Inc. instructions for building and many uses.

THE SMALLEST AND MOST EFFICIENT YET

SINCLAIR MICRO-INJECTOR

FOR FAULT FINDING AND SERVICING

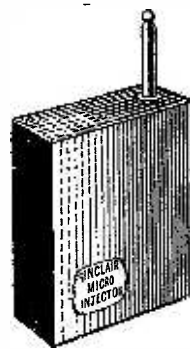

Using two MICRO-ALLOY TRANSISTORS, the Sinclair Micro-Injector is a precision sub-miniature instrument which generates and injects a test signal into any part of a receiver or amplifier at any frequency from 1 kc/s to 30 Mc/s. By this means, the position of any fault can be rapidly found.

This Micro-Injector is powered by a 6d. standard battery which will last for about 6 months. Size is $1\frac{1}{2}$ " x $1\frac{3}{10}$ " x $\frac{1}{2}$ ", excluding the $\frac{3}{16}$ " probe. Assembly is extremely simple and will take even a beginner only half an hour. With illustrated building and operating instructions.

TRACE THAT FAULT

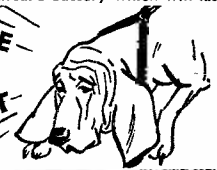

Total cost including all parts, MAT Transistors, printed circuit board, plated probe, and case in royal blue with gold trim. **27/6**

READY BUILT AND TESTED **32/6**

ALL EQUIPMENT UNCONDITIONALLY GUARANTEED

SINCLAIR radionics LTD. 69 HISTON RD. CAMBRIDGE

SINCLAIR 'SLIMLINE'

**THE SET YOU
WILL NEVER WANT
TO BE WITHOUT**



EUROPE IN THE PALM OF YOUR HAND!

*Fantastic Performance from this Micro-Transistor Receiver
build one for yourself—give one for Xmas!*

UNIQUE CIRCUITRY!

The secret of the Slimline's performance is in its unique circuit. This circuit, specially developed by Sinclair Radionics Ltd., makes full use of our incredible Micro-Alloy Transistors (MATs), and because of its ingenious design the quality of reproduction is outstandingly good with selectivity and sensitivity of an amazingly high order.

BUILD IT IN A COUPLE OF HOURS

The parts necessary to build this wonderful set comprise printed circuit board, sub-miniature components including MAT Transistors, case in royal blue and gold, featherweight high quality earpiece, etc. Full instructions with every order.

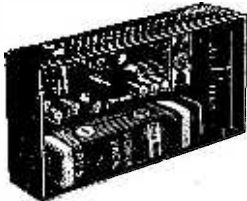

$2\frac{15}{16}'' \times 1\frac{11}{16}'' \times \frac{3}{4}''$
Total cost of parts including case and earpiece, but less battery.

49/6

Ideal as a Radio Jack

No matter what your experience with radio, the Sinclair Slimline is unique in its ability to give you reception in a way that no other set can. Its power and selectivity are truly phenomenal when you remember that this completely self-contained receiver is smaller than a packet of twenty cigarettes. It can be your companion everywhere, even letting you listen in car or train. Building is fascinatingly easy even if you have never built a set before in your life. If you are going to build and give one for Christmas, you had better order two—for once you have experienced making and listening to the Slimline, you won't want to be without one either.

"BEATS MY SEVEN-TRANSISTOR SET"

Thousands of Slimline Sets have been built and countless users have written expressing their enthusiasm. They have been used hundreds of miles out to sea, in the air, and in remote parts of Europe. Used as we are to receiving such letters even we were surprised by the following:

"Dear Sirs,

A friend of mine bought a Slimline and has used it from here to Aden with great success, equalling the performance, and at times beating my commercial seven-transistor set.

I am going on draft in another week and I would like very much to take a Slimline with me so could you rush the order through as soon as possible.

Yours sincerely," K.H.R., H.M.S. Dryad, Southwick.

- ★ INCREDIBLE VOLUME AND SENSITIVITY
- ★ TUNES OVER THE ENTIRE MEDIUM WAVEBAND
- ★ FULL SERVICE FACILITIES ALWAYS AVAILABLE

**POST
TO-DAY**

To SINCLAIR RADIONICS LTD., 69 HISTON ROAD, CAMBRIDGE

PLEASE RUSH..... FOR WHICH I ENCLOSE £..... s..... d.

NAME

ADDRESS.....

(Block letters please)..... RC.12

FREE!

DOUBLE-SIDED ^{VALUE} 5/-

BLUEPRINT

to build an
invaluable

MULTIRANGE TEST METER

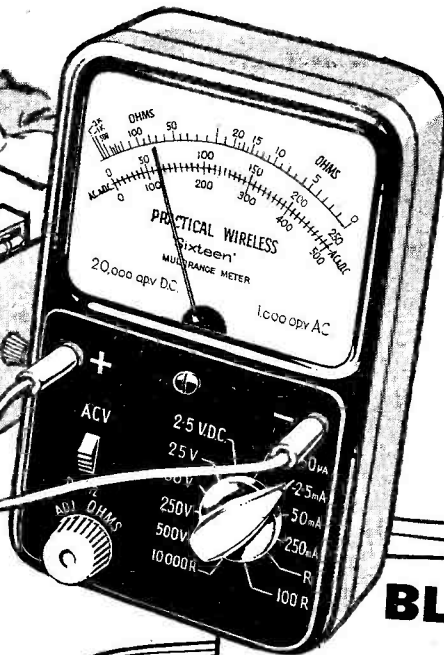
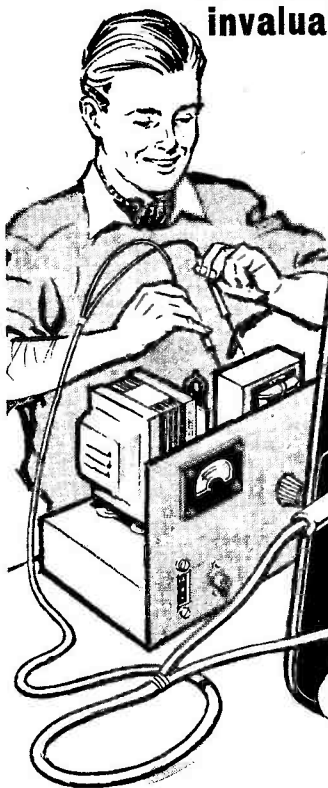

- 16 switched ranges; A.C. and D.C. operation
- Movement resistance 20,000 ohms per volt
- Easy-to-read scale
- Incorporates centre-pole movement
- Compact case, 3 $\frac{3}{4}$ " x 5 $\frac{3}{4}$ " x 1 $\frac{3}{4}$ "
- Components readily available

PLUS

COMPLETE GUIDE TO
TEST METER PROCEDURE

BLUEPRINT

INSIDE

ON SALE
DECEMBER 6th
BIG DEMAND!
ORDER FROM YOUR
NEWSAGENT TODAY!

PRACTICAL WIRELESS

JANUARY

2/-

THE MODERN BOOK CO

Frequency Divider Organs for the Constructor. By A. Douglas. 25s. Postage 9d.

Sound Facts and Figures. Pub. Focal. 12s. 6d. Postage 6d.

Single-Sideband Communications Handbook. By H. D. Hooton. 56s. Postage 1s.

Modern Tape-Recording and Hi-Fi. By K. Peters. 30s. Postage 1s.

The Transistor. An Introduction to its Applications. By E. Wolfendale. 21s. Postage 9d.

Electronic Musical Instrument Handbook. By N. H. Crowhurst. 20s. Postage 9d.

Radio Control for Models. By F. C. Judd. 15s. Postage 1s.

Radio Valve Data, 7th Ed. Compiled by "WW" 6s. Postage 10d.

The Radio Amateur's Handbook, 1963. By A.R.R.L. 36s. Postage 2s. 6d.

Elements of Electron Physics. By N. H. Crowhurst. 28s. Postage 1s.

Radio and Line Transmission. By G. L. Danielson and R. S. Walker, Vol. 1, 21s.; Vol. 2, 22s. 6d. Postage 1s.

Fun With Electronics. By G. Davey. 12s. 6d. Postage 1s.

Television Servicing Handbook. By G. J. King. 30s. Postage 1s. 3d.

Basic TV Course. By G. Kravitz. 30s. Postage 1s.

Wireless Servicing Manual. By W. T. Cocking. 25s. Postage 1s. 3d.

R.S.G.B. Amateur Radio Call Book, 1963. 4s. 6d. Postage 6d.

We have the Finest Selection of British and American Radio Books in the Country
New 1963 Catalogue 1s.

19-21 PRAED STREET (Dept RC) LONDON W2

Telephone PADdington 4185

MAXI-Q

COMPONENTS FOR THE "GENERAL COVERAGE COMMUNICATIONS RECEIVER"

as featured on page 263 in the November issue

COIL TURRET CT.7/B

This turret is the basic portion of the CT.7. It comprises cadmium plated steel frame (size $5\frac{1}{2}$ " deep x $4\frac{1}{2}$ " high x $3\frac{1}{2}$ " wide), silver plated contacts, polystyrene insulation and rotary turret movement incorporating Aerial, Mixer and Oscillator coils for the three bands 1.5-4 Mc/s, 4-12 Mc/s and 10-30 Mc/s. Price 75/-

Coil strips for the long and medium wavebands may be purchased separately for incorporation in the turret. Price 10/6 each

The turret requires a 315pF tuning capacitor. A suitable 3 gang component with ceramic insulation is available. Price 19/-

Air spaced concentric trimmers 3/30pF. Price 3/6 each

I.F. TRANSFORMER IFT.11/465 kc/s

A miniature I.F. Transformer for 465 kc/s giving excellent performance at low cost. Coils are litz wound and permeability tuned with high-grade iron dust cores and silver mica capacitors.

Screening Can $1\frac{1}{2}$ " x $\frac{1}{8}$ " square. Price 6/6 each

Also available for 1.6 and 10.7 Mc/s.

I.F. TRANSFORMER IFT.12/85 kc/s

A narrow band 85 kc/s I.F. Transformer for use in double superhet communications receivers. The overall response of one transformer is approximately 3.5 kc/s at 6dB. Dynamic resistance 500,000 ohms. Wound on a polystyrene former with iron dust core tuning and silver mica capacitors.

Price 16/- each

Also available for 100 kc/s.

BEAT FREQUENCY OSCILLATOR COIL BFO. 2/85 kc/s

These compact coils are wound on a bakelite former complete with adjustable iron dust cores and enclosed in an aluminium screening can measuring $1\frac{3}{8}$ " x $\frac{1}{8}$ " square. Price 5/- each

Also available for frequencies of 100 kc/s, 465 kc/s and 1.6 Mc/s.

General Catalogue covering full range of components, send 1/6 in stamps.

Please send S.A.E. with all enquiries

DENCO (Clacton) LTD. (DEPT. RC) 357/9 OLD ROAD
CLACTON-ON-SEA, ESSEX



Our cartoon is prompted by a recent request for our catalogue from a Persian Gentleman. It ran as follows:

Dear Sir, Mrs.,
Please send pure your general catalogues, addresses to. . . .

and then followed eleven addresses. No money was enclosed so we thought it might be a case of barter.

We tried to conjure up the list of items we might receive. We thought of Hookahs, Fezes, Yashmaks . . . and then we thought he might send us a small Harem, roof garden size. My fellow directors and I had almost finished washing a dozen catalogues in rose water to make sure they were pure, when our wives got to hear about it. Well fellow sufferers, you know wimmen . . . no

sense of humour! However, we can still dream. In the meantime a Happy New Year, and if it's not too late, a Merry Christmas!

And don't forget we still have some excellent catalogues (unwashed) at 3/6, post paid.

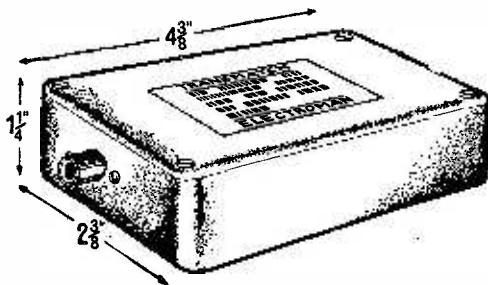

The TRANSMATCH

The Transmatch is designed as a Booster/Matcher for electric Guitars, Low Output Pick-ups, and Moving Coil and Ribbon Microphones. It measures only 4 3/8" x 2 3/8" x 1 1/4" and is completely self contained. Battery operated, it uses a High Quality Transistor, and one 2/- battery should last many months. It is simplicity itself to operate, the action of inserting the Jack Plug automatically switches it on, and it has been successfully used with a variety of low output electronic devices.

Price £3.10.6 P. & P. 1/6.

We stock printed circuits for the new MULLARD 3 and 10 WATT amplifiers using the audio triode pentode ECL.86 valve.

MONO 3 WATT 7/6P. & P. 1/6
STEREO 3 WATT 15/-P. & P. 1/6

MONO 10 WATT 12/6.....P. & P. 1/6
STEREO 10 WATT 25/-P. & P. 1/6

WE HAVE
ALL
HEATHKIT
MODELS
IN STOCK

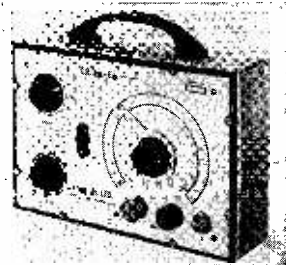

The NEW Nombrex Wide Range Transistorised C.R. Bridge.

Model 62

- 6 Ranges, 1 Ohm to 100 Megohm. 1pF to 100mF
- Visual Null Indicator
- Power Factor Check
- Electrolytic Leakage Test
- Battery operated

Price £7.2.3 P. & P. 3/6

HOME RADIO of MITCHAM

DEPT. RC, 187 London Road, Mitcham, Surrey. MIT 3282

Shop hours 9.0 a.m. to 6 p.m. (Wed. 1 p.m.)

THE Radio Constructor

Incorporating THE RADIO AMATEUR

Vol. 17, No. 5

Published Monthly

Annual Subscription 30/-
(including postage)

*Editorial and
Advertising Offices*

57 MAIDA VALE LONDON W9

Telephone
CUNningham 6141
(2 lines)

Telegrams
Databux, London

DECEMBER 1963

Modern "Three-Plus-One" T.R.F. Receiver, <i>by J. B. Willmott, A.M.I.P.R.E.</i>	300
Can Anyone Help?	305
Suggested Circuits No. 157: "Spares-Box" Voltage Measuring Instrument, <i>by G. A. French</i>	306
2-Watt 9-Volt Transistor Audio Amplifier, <i>by A. Kinloch</i>	309
Reaction Circuit for Reflexed Transistors, <i>by Sir Douglas Hall, K.C.M.G., B.A.(Oxon)</i>	310
Understanding Radio, Part 28, <i>by W. G. Morley</i>	312
Trade Review, The "Transmatch" Transistor Pre-Amplifier, Model TMU-1	316
News and Comment	317
Simple Electronic Rev. Counter, <i>by D. F. Warren</i>	318
Transistorised Television Circuits, Part 2, <i>by Gordon J. King, Assoc.Brit.I.R.E., M.T.S., M.I.P.R.E.</i>	319
Beam Deflection Tube Type 7360	323
In Your Workshop	325
Compact Constructor's Tuner, <i>by A. S. Carpenter, A.M.I.P.R.E.</i>	332
General Coverage Communications Double Superhet Receiver, Part 2, <i>by Frank A. Baldwin, A.M.I.P.R.E.</i>	338
Kit Review—Full Coverage F.M. Transistor Tuner	343
An Introduction to Colour Television, Part 7, <i>by J. R. Davies</i>	346
Christmas Castaway Contest	350
1963 Radio Communications Exhibition	351
Radio Topics, <i>by Recorder</i>	352

© Data Publications Ltd, 1963

We wish all our readers a very Happy Christmas and a
Prosperous New Year - Editor.

MODERN "THREE-PLUS-ONE"

T.R.F. RECEIVER

BY J. B. WILLMOTT, A.M.I.P.R.E.

This article describes the construction of a simple medium and long wave receiver which may be constructed at low cost employing readily obtainable components. It must be emphasised that a live chassis is employed and that all the relevant safety precautions, including the fitting of a cabinet back and complete isolation of accessible metal fittings, must be observed

PROBABLY THE TYPE OF RADIO RECEIVER WHICH has been built in the greatest numbers by home constructors of all ages is the familiar "Three-Plus-One" t.r.f. receiver. In post-war years complete kits of components, including a small plastic

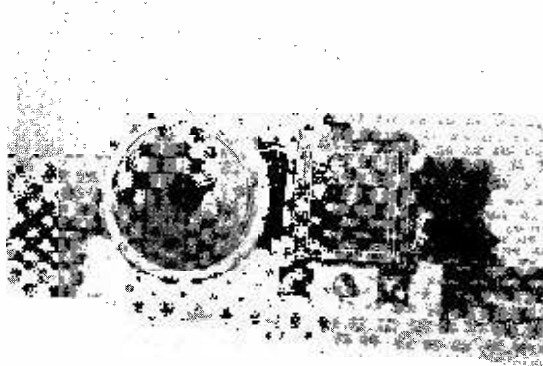

Front view of the completed receiver showing the method of dial mounting

or wooden cabinet to suit, have been marketed by numerous firms advertising in this magazine. The reason for the great popularity of these receivers is not far to seek; they are inexpensive to build, no specialised equipment is required for alignment, and in all but the poorest reception areas satisfactory reception of the local B.B.C. and a number of the more powerful continental stations on long and medium wavebands is assured. Owing to the inherent simplicity of their design, t.r.f. receivers of this type will give many years of trouble-free service and, being compact in size, they are ideal as a "second set" in a living room where t.v. takes pride of place, or for use as auxiliary receivers in a bedroom, kitchen or garage.

Valve Line-up

Practically all the kit sets have featured a line-up of international octal valves, a typical choice being 6K7, 6J7 and 6V6, together with a metal rectifier for h.t. supply and a heater transformer to feed the valve heaters and pilot lamp. These valves have always been cheaply obtainable on the surplus market, are robust and long lasting, and replace-

Components List

Resistors (all $\frac{1}{4}$ W 20% unless otherwise stated)

R ₁	220 Ω
R ₂	100k Ω
R ₃	2.2M Ω
R ₄	470k Ω
R ₅	15k Ω
R ₆	470k Ω
R ₇	100k Ω
R ₈	150 Ω $\frac{1}{2}$ W
R ₉	10k Ω 1W
R ₁₀	470 Ω 5W
R ₁₁	100 Ω 3W (see text)
VR ₁	10k Ω pot, lin track, with on-off switch

Rectifier

MR Contact cooled, to supply not less than 50mA at 250V

Capacitors

C ₁	500pF mica or ceramic 750V wkg*
C ₂	0.1 μ F paper 250V wkg
C ₃	0.1 μ F paper 250V wkg
C ₄	25 μ F 250V wkg electrolytic
C ₅	100pF mica or ceramic 250V wkg
C ₆	0.01 μ F paper 250V wkg
C ₇	25 μ F 250V wkg electrolytic
C ₈	8 μ F 350V wkg electrolytic
C _{9(a),(b)}	32 + 32 μ F 350V wkg electrolytic
C ₁₀	0.1 μ F 250V a.c. wkg paper
C ₁₁	0.01 μ F 250V wkg paper
VC _{1(a),(b)}	(a), (b), TC _{1(a),(b)} 2-gang 500pF tuning capacitor, with trimmers

* A lower working voltage for C₁ is permissible if the aerial is fully insulated along its length and at the end.

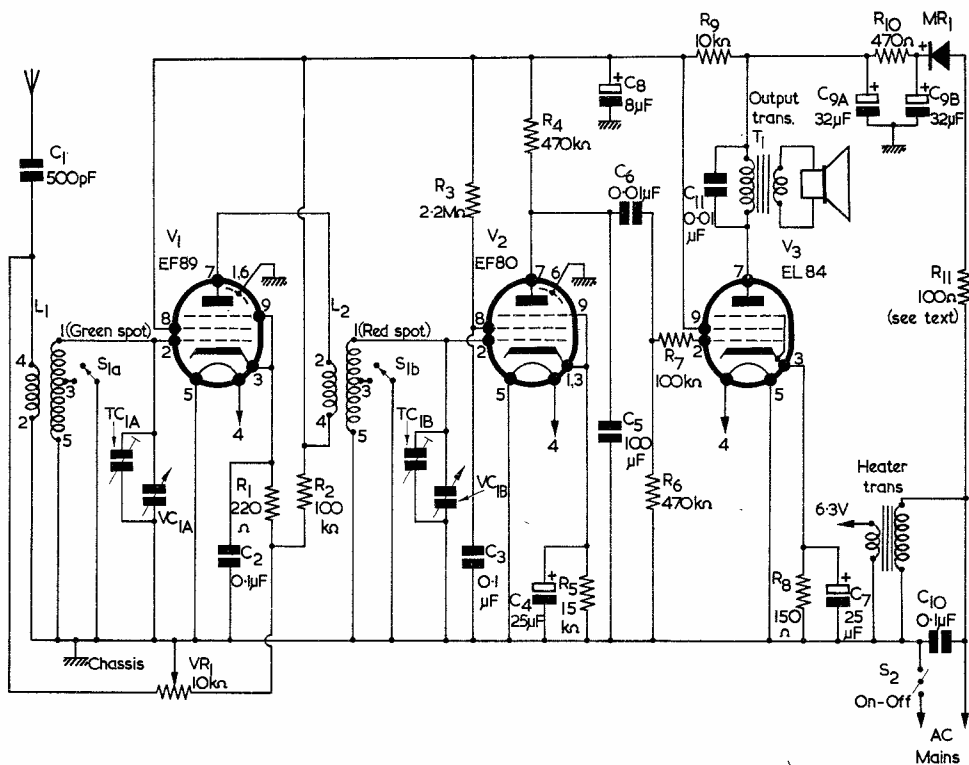

Fig. 1. Theoretical circuit diagram of the 3+1 t.r.f. receiver

Valves

- V₁ EF89
- V₂ EF80
- V₃ EL84

Transformers

- T₁ Pentode output transformer, 40:1 (5kΩ to 3Ω)
- T₂ Heater transformer, secondary 6.3V at 1.5A

Coils

- L_{1, 2} 1 pair matched Dual Range T.R.F. Coils (Lasky's Radio, Alpha Radio Supply Co., or Radio Supply Co.)

Switches

- S_{1(a), (b)} Wavechange, 2-pole 2-way, miniature
- S₂ On-off, part of VR₁

Loudspeaker

- 5in diameter, 3Ω

Miscellaneous

- 1 6.3V 0.15A pilot lamp and holder (bracket type)
- 3 B9A valveholders
- 3 3/8in grommets
- 1 3-way tagstrip

3 control knobs

- 1 TRF chassis (with dial, backplate, fixing brackets, etc.) (Lasky's Radio, Alpha Radio Supply Co., or Radio Supply Co.)
- 1 wood or plastic "Midget" cabinet to suit chassis (same suppliers)
- 1 cord drive complete (spindle, cord, tension spring, drum)
- 1 2-waveband glass dial for cabinet as above
- 1 double-ended brass tuning pointer
- Nuts, bolts, tags, wire, mains lead, etc.

ments are still, of course, easily obtained. However, the writer, who has assembled literally scores of these sets for friends and relatives (and cash customers!) in recent years, hit upon the idea of replacing the octal valve line-up with modern all-glass B9A valves, whilst at the same time carrying out other modernisation features. This has been done with such satisfying results that, owing to the fact that the all-glass valves can now be obtained at prices very little higher than the older octal pattern, all future requests for receivers of this sort are being assembled to the revised specification described in this article. The highly efficient modern valves have added very noticeably to the sensitivity and selectivity, whilst reproduction, bearing in mind the use of a small diameter 5in loudspeaker, is most pleasing.

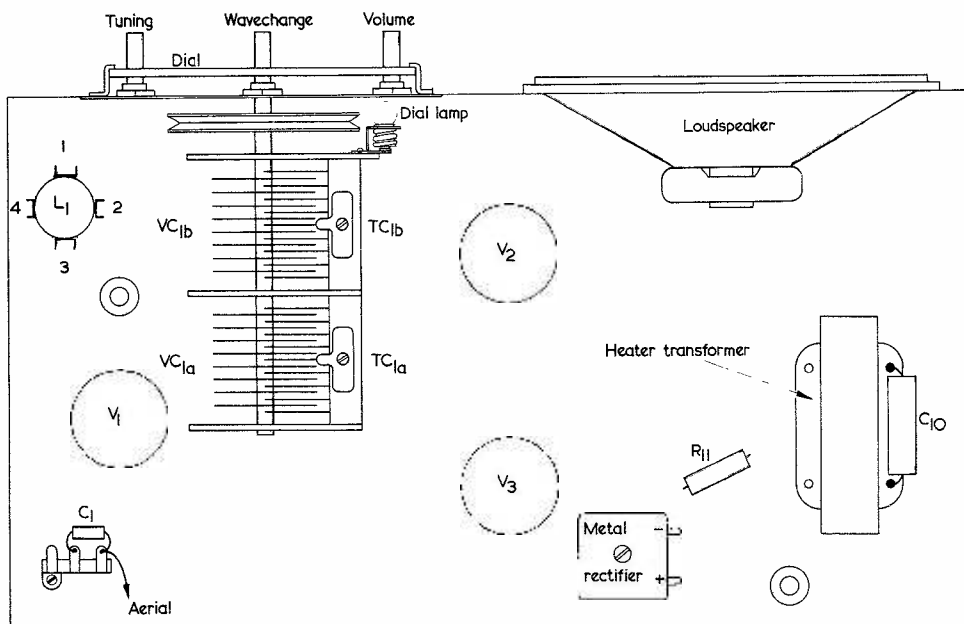

Fig. 2. Above-chassis main component layout (not to scale)

All components are readily obtainable from advertisers in this magazine, including a ready drilled chassis (whose only major modification comprises filling-in of the octal valveholder apertures with small pieces of aluminium cut out to accommodate the $\frac{3}{4}$ in diameter B9A valveholders) and a cabinet and dial assembly to suit. The total cost, even if everything has to be purchased, is moderate, and most constructors will have many of the required resistors and capacitors, etc., already in their spares box. Indeed, some constructors may be carrying out the project in the form of the reconstruction of an existing t.r.f. receiver, in which case most of the original components, if in good condition, can be retained. Considerable latitude in layout and choice of components is permissible in a receiver of this sort without any deleterious effect on performance, provided of course the elementary rules of short and direct wiring are adhered to.

Circuit Description

Mainly for the benefit of less experienced constructors, a brief description of the circuit will not be out of place at this point. The title "Three-Plus-One" is a common appellation for receivers comprising a single valve stage of radio frequency amplification, followed by a combined detector/audio amplifier valve stage and, finally, by a power output stage—hence the "Three" in the title. The whole is then fed from a further valve (or metal) rectifier, this being the "Plus-One".

Referring to Fig. 1, signals are applied via the isolating capacitor C_1 to the primary winding of the aerial tuning coil L_1 , which is one of a matched

pair of Dual Range t.r.f. coils. The secondary winding is tuned by one section of the 2-gang tuning capacitor, $VC_{1(a)}$, the desired signal being applied to the control grid of the r.f. amplifier valve, V_1 . This is an EF89 which, being of the variable-mu type, is provided with a gain (volume) control, VR_1 , in the cathode circuit. Fixed minimum bias is provided by R_1 , and the far end of VR_1 is returned to the aerial input end of the primary winding of L_1 . This has the effect of virtually short-circuiting the aerial to chassis at minimum volume setting. Without this connection, it might be found impossible to reduce the volume sufficiently on strong local signals. The inclusion of R_2 between the main h.t. positive line and the junction of R_1 and VR_1 will be found helpful in ensuring a wide and smooth range of variation in volume control.

After amplification in V_1 , signals are passed to the control grid of V_2 via the r.f. transformer coupling provided by L_2 , which has its secondary winding tuned by the second section, $VC_{1(b)}$, of the 2-gang tuning capacitor. V_2 is an EF80, which is a high slope straight pentode, and it is employed here to provide anode bend rectification. This method of rectification is the most suitable for simple mains-operated receivers, as there are far less risks of introducing troublesome mains hum than with the more sensitive grid leak detector. Also, the loading on the previous tuned circuit is much less, giving a worthwhile degree of improved selectivity. In theory, anode bend detectors introduce a high level of distortion but it is found in practice, particularly when the output is being fed to a small loudspeaker of only limited frequency

response, that the arrangement is quite satisfactory. In order to provide correct operating conditions a high value of anode load, R_4 (470k Ω), together with a higher than normal value bias resistor R_5 (15k Ω) and a screen feed resistor of 2.2 M Ω (R_3), is specified, and the values quoted should be strictly adhered to if distortion is to be avoided.

The demodulated (a.f.) signal is now present at the anode of V_2 , together with a residue of unwanted r.f. This latter is filtered away to chassis by C_5 , and the a.f. signal applied to the grid of the beam tetrode output valve V_3 by way of C_6 . R_7 , a grid stopper resistor, is inserted as close as possible to the grid pin of V_3 to finally block any residual r.f. from reaching this valve. V_3 is an EL84 which, by virtue of its high "slope", is capable of giving maximum power output with a comparatively modest input to its control grid. In common with all high-slope valves, however, instability can be caused if unwanted r.f. is allowed to reach the control grid, and hence the need for R_7 .

The output from V_3 is matched to the loudspeaker by the output transformer, across the primary winding of which is connected a 0.01 μ F tone correction capacitor to counteract the tendency of V_3 to accentuate the higher frequencies.

Power supply for the receiver makes use of a heater transformer to provide the necessary 6.3V at about 1.5 amps required for the valve heaters and pilot bulb. H.T. is obtained by half-wave rectification direct from one side of the mains supply, a modern contact-cooled metal rectifier being utilised. One side of the mains supply is, of necessity, connected to the chassis of the receiver, hence

the need for the aerial isolating capacitor C_1 , and for ensuring that, when completed, the set is housed in a totally enclosed cabinet. It is also necessary to ensure that grub screws in control knobs are covered with wax or other insulating substance to prevent any risk of shock to the operators, and that no live points whatsoever are accessible.

Returning to the question of the h.t. supply, better-than-average smoothing circuits are incorporated in the present design, as it is a common failing of many small t.r.f. receivers that the hum level is unpleasantly high. The two stages of resistance capacitance smoothing incorporated provide a complete cure to hum troubles. R_{10} , which is a wirewound resistor of 470 Ω , 5 watts, in conjunction with the dual-section electrolytic capacitor $C_{9(a), (b)}$, provides an adequately smoothed h.t. supply of some 230V to the anode of V_3 ; whilst further smoothing, afforded by R_9 and C_8 , provides a ripple-free voltage of approximately 180 volts for the screen grid of V_3 , and the anode and screen grid supplies of the remaining stages of the receiver.

Wavechange switching is provided by $SW_{1(a)}$ and $SW_{1(b)}$, which can conveniently be a 2-pole 2-way Yaxley switch. This is so connected that, in the medium wave position, the lower (long wave) windings of L_1 and L_2 are simultaneously short-circuited to chassis. The tag numbering of the coils shown in Figs. 1, 2 and 3 is that for the coils used in the prototype (and specified in the components List). If coils of different manufacture are used, the relative maker's instructions as to connection data must of course be adhered to.

The tuning capacitor is operated by a simple but

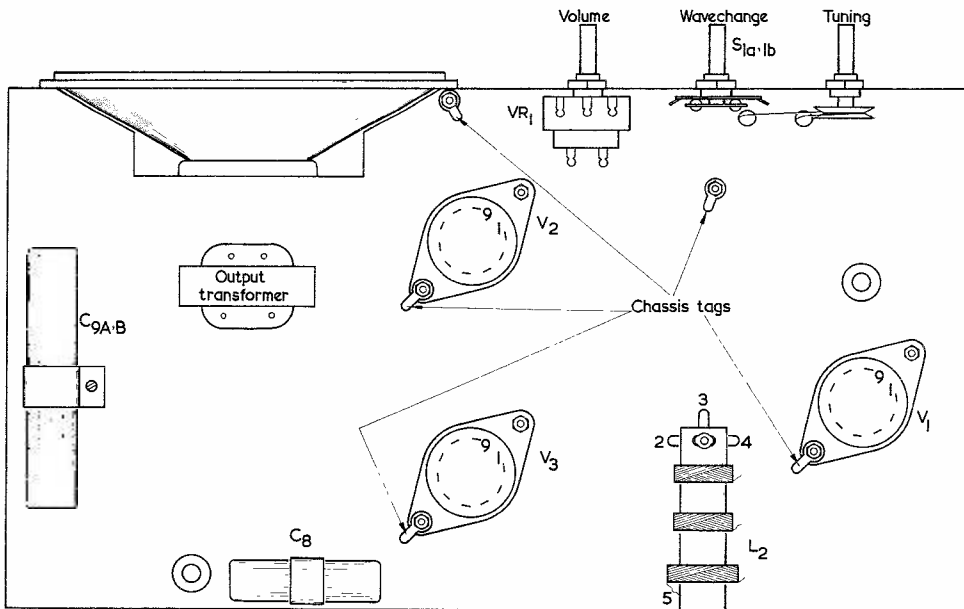
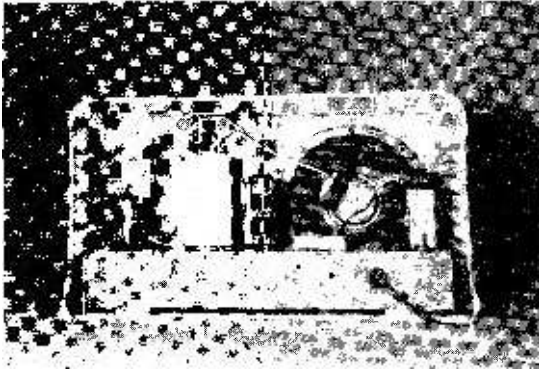

Fig. 3. Below-chassis layout of main components (not to scale). All small resistors and capacitors are supported in the wiring and are not shown here as their exact positions are not critical

reliable cord and drum system, this being driven from the tuning spindle shown in Figs. 2 and 3. A small brass double-ended pointer is attached to the tuning capacitor spindle (which projects through a hole in the dial backplate) and this, in conjunction with a suitable glass dial, gives correct tuning indication. The glass dial can either be held in place by four brass clamps fastened to the dial backplate, as in the photographs, or can be glued to the inside of the cabinet "window".

Assembly and Wiring

The assembly and wiring of this receiver is extremely straightforward, the only points of special note being the correct orientation of the valveholders and the aerial and r.f. coils (see Figs. 2 and 3), so as to ensure short and direct wiring. The heater transformer (above chassis) and the output transformer (below chassis) are mounted so that their cores are at right angles to one another, thereby minimising any tendency to interaction which might otherwise occur. Solder tags for chassis connections should be affixed to one of the holding down bolts of each valveholder, additional solder tags being also provided on one of the loudspeaker fixing bolts and on one of the bolts securing the front end of the two-gang tuning capacitor. The position of all these tags is clearly shown in Fig. 3.



Chassis view of the t.r.f. receiver showing the 100Ω surge limiting resistor connected between the "live" side of the a.c. mains and the input to the metal rectifier

Fig. 2 shows the position and function of the 3-way tagstrip mounted above the chassis adjacent to V_1 , this providing anchorage for the aerial lead and the isolating capacitor C_1 . Rubber or p.v.c. insulating grommets should be fitted in the holes providing access for leads to L_1 and the heater transformer, and in the hole in the rear chassis runner which provides entry for the mains supply lead. All components which require securing to the chassis should be mounted before wiring is commenced.

It will be noticed that the large electrolytic capacitors C_8 and C_9 (a), (b) are secured by clips made

from small scraps of aluminium. The cord drive to the main tuning capacitor should be wrapped twice around the driving spindle to ensure a firm slip-free drive, and the pointer should be positioned so that it lies horizontal when the gang is in the fully closed position. Make sure that the drive mechanism operates smoothly before proceeding further.

It is recommended that wiring commence with the mains input to the heater transformer, including the on/off switch (which is integral with the volume control VR_1), followed by the heater supply to the three valves and pilot lamp. Only one run of wire is required here, as the heater return connection is provided via the chassis. The r.f. wiring to the dual-range coils and wavechange switch can conveniently follow, then the a.f. signal path from V_2 anode through to the output transformer in V_3 anode circuit. Next, wire up the cathode circuits of each valve, including VR_1 in the case of V_1 , and taking care to observe correct polarity of the electrolytic capacitors C_4 and C_7 .

Lastly, wire up the h.t. supply, starting from the mains input to the metal rectifier, and following it in logical sequence to the anodes and screen grids of each valve in turn, not forgetting decoupling capacitors where indicated. Make sure that VR_1 is connected in the correct "sense" so that clockwise rotation gives a reduction in the total resistance in circuit between the cathode of V_1 and chassis (and hence an increase in volume). Note also that, as the main smoothing resistor R_{10} will run quite warm in use, this component should be mounted well clear of the chassis surface and of surrounding components or wiring.

Another feature of importance is that the $0.1\mu F$ capacitor in the C_{10} position, which is for the purpose of reducing mains-borne interference, must be able to withstand the impact of the full mains voltage at all times, and for this reason should be a component of 250 volts a.c. working. Obviously a breakdown of this component would produce a dead short-circuit across the mains supply, possibly with serious consequences.

Thoroughly check all wiring for possible errors or omissions, and if a test meter is available, test for possible short-circuits or low resistance paths between the h.t. positive line and chassis. Insert the valves, taking care to see that they are in their correct relative positions, that is, the EF89 nearest the end of the chassis, the EF80 adjacent to the loudspeaker, and the EL84 near the rear edge of chassis.

Testing and Alignment

Connect a short throw-out aerial, for which approximately 12ft of insulated flex is suitable. Remember that, as the chassis of the receiver is connected to one side of the mains supply, on no account may any form of earth connection be made thereto. Also, when handling the chassis or control spindles, make sure that one is standing on a dry wooden floor. Set the wavechange switch to medium waves, insert the mains plug, and switch on. Provided that the pilot bulb illuminates straight

away, that the valve heaters can be seen glowing normally in a few seconds, and that there are no signs or sounds of stress or overheating elsewhere, advance the volume control. Rotation of the tuning control should quickly locate the local B.B.C. programme, whereupon a rough adjustment of the trimmers $TC_{1(a)}$ and $TC_{1(b)}$ should be made to peak up the volume. Now search for a transmission at the high frequency end of the dial, such as the B.B.C. Light Programme on 247 metres or, better still, Radio Luxembourg on 208 metres and, having located same, carefully adjust the trimmers for maximum volume. Some slight adjustment of the dial pointer may be needed in order to achieve a correct station indication on the dial consistent with maximum volume. It should now be found, on swinging the tuning control over its range, that a number of stations are received at their correct positions on the dial (provided, of course, that a properly matched set of coils and dial have been purchased). On switching to the long waveband it should be found that the B.B.C. Light Programme on 1,500 metres is receivable at the correct dial setting without further adjustment.

In some locations it may be found that there is a slight residual hum discernable in the output. If this is the case, reversal of the mains plug in its socket (or of the connections thereto in the case of a non-reversible 3-pin plug) will effect a cure. If the receiver has been correctly assembled a very

pleasing standard of reproduction should result, with more than ample volume from the principal stations. A "picture rail" aerial, or connection to the screening braid of a t.v. aerial downlead, should be adequate in all but the poorest reception areas. If construction has taken the form of modification of an existing octal valved t.r.f. receiver, a worthwhile increase in performance will be readily observable.

Constructors may note, in the above-chassis photograph, a resistor connected between the "live" side of the mains and the input to the metal rectifier. This is actually a 100Ω surge limiting resistor which was incorporated in the prototype. However, a number of subsequent versions of this receiver have been built without this component and with no observable ill effects. Doubtless the modern type of contact cooled metal rectifier is well able to withstand the surge caused by initial charging up of the high value reservoir capacitor, and the 100Ω resistor may therefore be omitted.

EDITOR'S NOTE.—*Without specifying the rectifier and reservoir capacitor by make and type number it is difficult to state what surge currents may be acceptable. To be safe, we would recommend the inclusion of the 100Ω resistor (which is shown as R_{11} in Fig. 1), since excessive surge current may cause damage not only to the rectifier but also to the reservoir capacitor and the on-off switch. Constructors who omit the resistor do so at the risk of damaging these components.*

CAN ANYONE HELP?

Requests for information are inserted in this feature free of charge, subject to space being available. Users of this service undertake to acknowledge all letters, etc., received and to reimburse all reasonable expenses incurred by correspondents. Circuits, manuals, service sheets, etc., lent by readers must be returned in good condition within a reasonable period of time.

Admiralty Pattern No. W5799 Test Set SE2.—F. B. Gowen, G3RQN, 61 Westerleigh Road, Yate, Bristol, requests the loan of circuit diagram or any other information.

* * *

3582A Receiver, Indicator Unit CRT Type 26.—S. S. Forster, Hermitage Turkey Farm, Holmes Chapel, Nr. Crewe, Cheshire, requests any available information on these units.

* * *

Aircraft Radio Type CW46048D.—A. F. Ayles, 1 Ridgeway Drive, Bromley, Kent, would like to obtain the manual or circuit of this American receiver (part of Equipment RU19) on purchase or loan, all expenses gladly refunded.

1392D Receiver.—K. J. Williams, 60 Gladstone Avenue, London, N.22, wishes to purchase, borrow or hire, the manual for this receiver.

* * *

Magazine Back Issue.—W. L. Brunson, 56 Greenwood Lane, Wallasey, Cheshire, would like to obtain, on loan or purchase, *The Radio Constructor* dated May 1955.

* * *

PR7NA Receiver.—E. Brown, 9 Grove Road, Sevenoaks, Kent, requires any information, circuit, etc., on this receiver.

* * *

Receiver Type W5737.—J. Warburton, 110 Buckingham Road, Cheadle Hulme, Cheadle, Cheshire, would like to purchase, or obtain on loan, the circuit for this receiver.

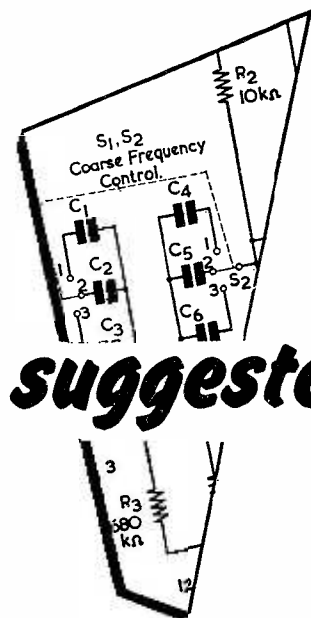

The circuits presented in this series have been designed by G. A. French, specially for the enthusiast who needs only the circuit and essential data

suggested circuits

No. 157 "Spares-Box" Voltage Measuring Instrument

FROM TIME TO TIME THE WRITER receives requests from readers for "Suggested Circuits" on particular applications, and these requests are always welcome. In some cases the applications asked for tend to be impracticable or of a nature which cannot be covered by a circuit on its own without a considerable amount of practical information, but in most instances it is possible to satisfy readers' requirements completely. Whilst requests are usually for somewhat complex projects, there are occasional letters from beginners who require information on inexpensive test equipment and similar subjects.

The present article is, in consequence, aimed specifically at the beginner, and it describes a simple device for measuring alternating or direct voltages which may be assembled for several shillings only. The few parts required are not in any way critical so far as values are concerned, and suitable components may already be available in the spares box. The measuring instrument is capable of indicating a.c. or d.c. potentials over a range of some 100 to 500 volts, and it offers a relatively high resistance to the terminals at which measurements are to be taken. In this respect it is commensurate with a medium-grade moving-coil voltmeter, but it is not quite as accurate as the latter, nor

is it as convenient to use. It is felt, however, that these two shortcomings are justified by its very much lower cost. Another point is that the present instrument can be assembled in a small case and that it is considerably more robust than a

The Circuit

The circuit of the voltage measuring instrument is illustrated in Fig. 1. In this diagram R_1 is a $500k\Omega$ linear potentiometer, the outer ends of its track being connected, by way of two test prods, to the voltage to be measured. The potentiometer is provided with a scale which is calibrated in terms of voltage. A neon bulb, in series with the $1M\Omega$ resistor R_2 , is connected between one end of the track and the slider.

To take a reading, the test prods are connected to the voltage to be measured, and the slider of R_1 is adjusted from the lower end of its track. As a result, the voltage applied to the neon and R_2 in series increases. When this voltage becomes equal to the striking voltage of the neon, the latter suddenly becomes illuminated. The setting of R_1 which causes the neon to strike depends upon the voltage applied to the test prods, and this voltage may then be read from the scale fitted to the potentiometer.

R_1 requires two scales, one for direct voltage and one for r.m.s. alternating voltage. The reason for having two scales is that, with alternating voltages, the neon lights when the peak value of the applied voltage becomes equal to its striking potential. Since it is preferable to calibrate R_1 in terms of r.m.s. rather than peak alternating voltage,

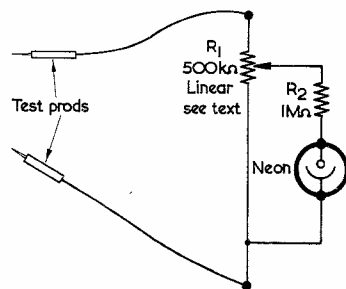

Fig. 1. The circuit of the simple voltage measuring instrument

moving-coil voltmeter. It may, therefore, be safely and conveniently carried around either in the pocket or in a tool kit. It is worth adding that devices employing the same principle as that described here have been offered commercially in this country for measuring e.h.t. voltages, and are currently available in America for measuring potentials up to some 650 volts.

a second a.c. scale is needed, this being marked up with values equivalent to 0.7 times the corresponding direct voltages. To take an example, let us assume that the test prods of the instrument are applied to a known source of 100 volts d.c. and that R_1 is adjusted until the neon strikes. The requisite setting of R_1 then corresponds to a direct voltage of 100 and may be calibrated accordingly. If an alternating voltage having a peak value of 100 is next applied to the test prods, the neon will strike at the same setting of R_1 as occurred in the previous instance. Since, however, it is desirable to calibrate the a.c. scale in terms of r.m.s. voltage, this setting of R_1 will now correspond to 70 volts on the a.c. scale.

This relationship between peak and r.m.s. voltages applies only to sinusoidal a.c. waveforms. If the alternating voltage being measured is markedly non-sinusoidal it may, in any event, be preferable to work in peak voltages, whereupon these can be read directly from the direct voltage scale.

Alternative Circuits

A number of experimenters find that a neon bulb and series resistor are useful in simple tests for such things as insulation or capacitor leakage. In consequence, it may be considered desirable to modify the circuit of Fig. 1 such that the combination of neon and series resistor can be applied to the test prods on its own. Fig. 2 (a) shows one simple arrangement employing an s.p.s.t. switch. For voltage measurements, this switch is closed, and the test prod leads are inserted into sockets 1 and 2. To use the neon and series resistor combination on its own the switch is opened, and the test prod leads are fitted into sockets 1 and 3. In Fig. 2 (b) a d.p.d.t. switch is required, and the test prod leads may be connected to the unit permanently, as no sockets are required. When the switch is in position A, the circuit is the same as that of Fig. 1. When the switch is in position B, the test leads connect to the neon and series resistor combination on its own. A third alternative using an s.p.s.t. switch is shown in Fig. 2 (c). In this circuit, opening the switch causes the neon to be connected in series with R_2 and the upper part of the track of R_1 . If the slider is set to the top of its track, the series combination of R_2 and the neon is effectively applied to the test leads. Closing the switch makes the circuit equivalent to that of Fig. 1.

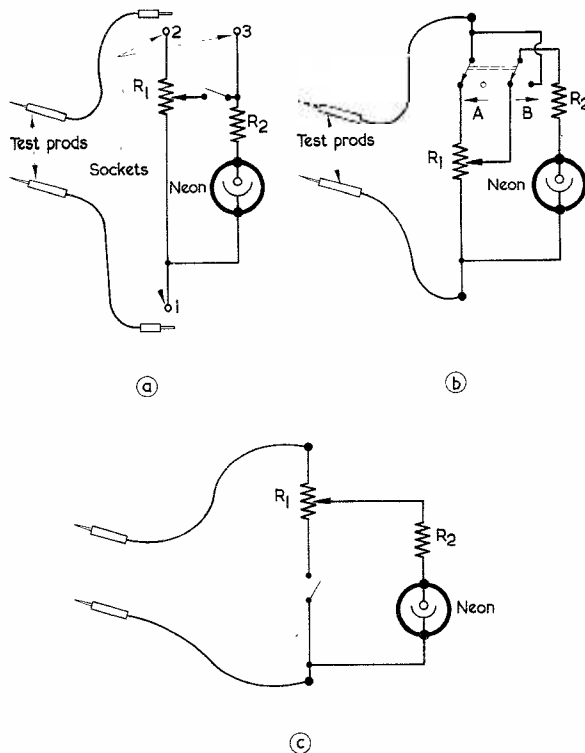

Fig. 2 (a). A modification which allows the combination of neon and series resistor to be applied on its own to the test prod leads. The test leads are terminated in wander plugs which fit into sockets 1, 2 or 3
 (b). Another modified circuit which does not require sockets at the instrument
 (c). A simpler circuit which also enables the neon and series resistor combination to be presented to the test leads

Practical Points

In order to check the usefulness of the measuring instrument, the writer constructed a prototype circuit using the component values shown in Fig. 1. The neon was taken from an inexpensive "neon screwdriver" of the type employed for checking live mains points. Neons of this type normally have low striking voltages and give a glow which can be very readily discerned. The type of neon used is not critical, however, provided that it is small in physical size and has a striking voltage of the order of 100 or less.*

It was found, with the prototype, that the setting in R_1 needed to cause the neon to strike was very well defined and could be re-determined with complete accuracy

* If one of the circuits of Fig. 2 is used, the measuring instrument may be employed to identify live mains points in the same manner as a "neon screwdriver".

on successive occasions. Test with alternating and direct voltages also confirmed the relationship referred to above, i.e. that a.c. r.m.s. voltages correspond to 0.7 times the d.c. calibration for R_1 . With alternating voltages it was found that the setting in R_1 which caused the neon to extinguish after illumination was virtually the same as that needed to cause it to strike; whilst, with direct voltages, the difference between these two settings was equal to several degrees of potentiometer rotation. The effect given by the alternating voltage is, of course, to be expected, since the neon then strikes and becomes extinguished twice during each cycle.

It would be possible to calibrate R_1 in terms of the voltage which caused the neon to extinguish as the slider is moved to the lower end of its track, but this course is undesirable for two reasons. Firstly,

the neon would draw current from the source of voltage until the instant it extinguished whereas, with the method recommended here, the only current flowing up to the instant of striking is that drawn by the potentiometer on its own. Secondly, calibration against neon extinction would not result in the simple numerical relationship between d.c. and a.c. r.m.s. ranges which occurs with the case where the neon strikes.

Components and Construction

The components employed may, as has already been stated, be inexpensive types, and their values are not critical. The choice of neon has already been dealt with.

The potentiometer R_1 may be any carbon track linear potentiometer of standard dimensions. A fairly new component should be used, since a heavily-worn track will result in unreliable operation and a departure from linearity. The value specified for this component in Fig. 1 is $500k\Omega$ although, in practice, any value between this figure and $1.5M\Omega$ would be satisfactory. It would be preferable to limit the potential appearing across the track to about 500 volts, which then represents the maximum voltage the instrument should be used to measure. This voltage also infers a dissipation of $\frac{1}{2}$ watt in the track of R_1 when this potentiometer has a value of $500k\Omega$, and such a dissipation should be satisfactory for intermittent use.

The series resistor R_2 can be any fixed component having a rating of $\frac{1}{2}$ watt or more, and a tolerance of 20%.

The switches employed in the circuits of Fig. 2 could conveniently be toggle or slide types. If the latter, care should be taken to ensure that ratings are adequate for the voltages to be handled.

The completed unit may be housed in a case of convenient size, a suggested panel layout (corresponding to Fig. 2 (b) or (c)) being given in Fig. 3. Since the unit will be connected to relatively high voltages,

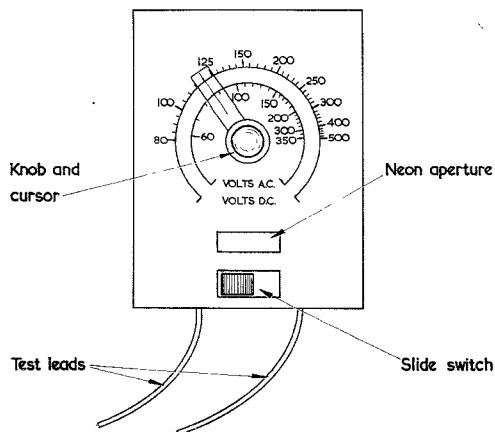

Fig. 3. A suggested panel layout for the circuits of Fig. 2 (b) or (c). The scale is representative of what would be offered if the neon had a striking potential of 75 volts

the case should be made of an insulating material, and the knob and cursor for the potentiometer so fitted that the spindle, and metal parts in contact with it, cannot be touched. Fig. 3 also shows a typical voltage scale which indicates the relationship between d.c. and r.m.s. a.c. values. It will be noted that voltage figures increase as the potentiometer is turned clockwise. This corresponds to the instance where the clockwise potentiometer tag (spindle towards the reader) is that which is common to the neon.

Calibration

Instruments employing the circuits given in Figs. 1 and 2 will need to be calibrated individually, since calibration points depend upon the striking voltage of the neon which is employed. Calibration should be carried out against at least four known direct voltages, one of these being slightly higher than the striking voltage of the neon, and another slightly below, or at, the highest voltage in the range. All

these voltages should correspond to settings in R_1 which are removed from the ends of the track (where there may be a tendency towards non-linearity). The readings obtained should then be plotted on a graph, a final calibration curve being obtained and used for making up the d.c. scale. The a.c. range may next be added by the simple process of multiplying the d.c. figures by 0.7. The accuracy of the a.c. range should, finally, be confirmed by checking a known alternating voltage.

Some neons may give different displays for direct voltages of opposing polarity. Should this be the case, the instrument may then also be used to provide an indication of polarity as well as of voltage. If it is found that a more noticeable display is given by one particular polarity, the test leads should be given corresponding colours. Calibration, and subsequent measurements, should then be carried out using the polarity which gives the more noticeable indication.

RADIO AIDS IN NEW CUNARDER

Technicians from the Newcastle-on-Tyne depot of The Marconi International Marine Company, Limited, have installed communications equipment and radio aids to navigation in the new cargo liner *Media*, 7,300 tons.

Built on Tyneside by John Readhead & Sons, South Shields, for Cunard Steam-Ship Co., Ltd., the *Media* employs an "Oceanspan VII" transmitter with an "Atalanta" receiver for worldwide communication by radiotelegraphy on medium and high frequencies, and facilities are provided for radiotelephone operation on the intermediate frequency marine band. A "Salvor II" transmitter with "Autokey" device, "Alert" guard receiver and "Lifeguard" auto alarm receiver provides a complete emergency installation.

Long-range wireless bearings are provided by a "Lodestar" automatic direction-finder; and an "Argonaut" VHF transmitter/receiver provides facilities for short distance radiotelephone communications.

2-Watt 9-Volt TRANSISTOR AUDIO AMPLIFIER

BY A. KINLOCH

A simple and efficient amplifier which has the incidental advantage of employing transistors which are available on the components market at low prices

THIS AMPLIFIER, WHICH OPERATES FROM A 9 VOLT supply, can provide 2 watts output into a 3Ω loudspeaker. Though the prototype has been used only to amplify the output from a transistor tuner, it should have many other applications.

The Circuit

The three-stage circuit comprises a grounded-emitter pre-amplifier RC-coupled to the grounded-emitter driver TR₂ which, in its turn, is directly coupled to the output transistor TR₃. D.C. and a.c. feedback is provided by a resistor connected between the emitter of the output transistor and the base of the driver transistor. The output transistor is coupled to the 3Ω loudspeaker by a 1.3:1 ratio transformer.¹ The type specified in the Components List is intended for a push-pull output stage but, as the laminations are butt-jointed and it is rated at 10 watts, the core should not become saturated by the 1 amp quiescent current. The two primary and secondary windings should be connected in series.

The output transistor should be mounted directly on a 7 x 7in 16 s.w.g. aluminium plate. It must be remembered that this plate will then be connected

collector of the output transistor.² In the prototype OC81's were employed in the TR₁ and TR₂ positions. Improved results may be given by using ACY21's in these positions, but this has not been checked in practice.

Setting Up

Setting up of the amplifier is best carried out using dry cells. The 5kΩ pre-set potentiometer is set about halfway between its extreme positions before power is applied. It is then adjusted until the quiescent collector current of the output transistor is 1 amp.

The amplifier can easily be constructed using group-board or printed circuit techniques, both of which have been described in previous issues of this magazine.

² It may be preferable to employ a 5 x 7cm 16 s.w.g. aluminium heat sink for TR₂.—Editor.

Components List

Resistors

(All fixed resistors are 10% ¼ watt unless otherwise stated)

- R₁ 39kΩ
- R₂ 10kΩ
- R₃ 2.2kΩ
- R₄ 1kΩ
- R₅ 560Ω
- R₆ 47Ω 1 watt
- R₇ 2.2kΩ
- R₈ 1Ω 2 watt wirewound
- VR₁ 5kΩ potentiometer pre-set

Capacitors

(All capacitors are electrolytic)

- C₁ 10μF 12V wkg
- C₂ 100μF 3V wkg
- C₃ 10μF 12V wkg
- C₄ 100μF 12V wkg

Transformer

Repanco Type TT24. 1.3 + 1.3 : 1 + 1. See text

Transistors

- TR₁ OC81, ACY21. See text
- TR₂ OC81, ACY21. See text
- TR₃ OC25, XC141

¹ Actually a 1.3+1.3 to 1+1 transformer. This does not give optimum matching at low frequencies; matching approaches optimum as the impedance of the speaker rises with frequency.

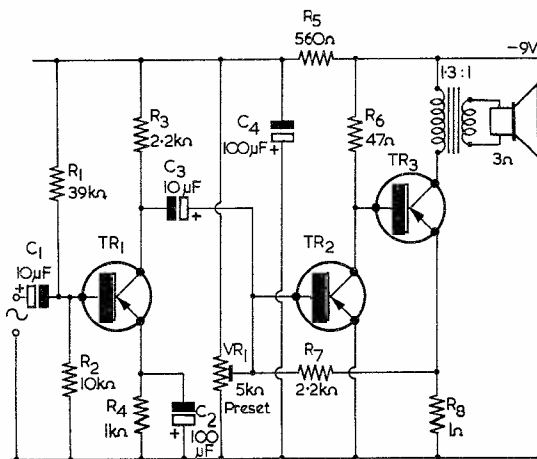

REACTION CIRCUIT FOR REFLEXED TRANSISTORS

Sir Douglas Hall, K.C.M.G., B.A. (Oxon)

Reflex transistor t.r.f. circuits can offer a very good performance, particularly when regeneration is employed. In this article our contributor describes a circuit which, at the expense of additional components, enables the regeneration control to function as an a.f. gain control also, with the added advantage that oscillation point appears at a constant setting throughout the band

CIRCUITS USING TWO TRANSISTORS in a reflex arrangement providing two stages of radio frequency and two stages of audio frequency amplification are popular and very efficient within their limitations. Fig. 1 shows a typical arrangement and is, in this instance, that used in the "Pocket 4" radio kit.¹

It is important to obtain as much high frequency amplification as possible and it is also necessary, in the interests of both sensitivity and selectivity, to use reaction. One difficulty is that, in many cases, the reaction circuit itself reduces the real radio frequency amplification because of losses due to stray capacitances and other shunts across the high frequency load of the second transistor.

A disadvantage of the simple single tuned circuit reflex receiver is that there is no true volume control (so that local stations cannot be brought down to a whisper), or there is pre-set reaction and an audio frequency volume control (which can result in over-loading from local stations). In addition nearly all reaction circuits involve variation of the reaction control in accordance with the frequency of the station being received.

Maximum Amplification

The author has carried out experiments to produce a circuit which offers the maximum true radio frequency amplification which

can be obtained with two transistors and a single tuned circuit, together with a reaction control which can, firstly, be set to one position to produce maximum regeneration over the whole of the medium waveband and which, secondly, controls audio frequency amplification for the first part of its travel.

In the circuit in Fig. 1, reaction is obtained by means of tapping off from the collector load of TR₂ a small proportion of the radio frequency signal and feeding it back through C₁ to the tuned circuit, control being effected by R₁. If two

highly efficient surface barrier transistors are used in the circuit, however, it will be found that the diode has sufficient self-capacitance on its own to feed back enough of the amplified signal to bring about oscillation, and in Fig. 2 it will be seen that C₁ of Fig. 1 has been done away with. R₃ in Fig. 2 is the radio frequency load for the diode and R₂ the audio frequency load. R₁ is included in the circuit to prevent spurious oscillation, particularly at the high frequency end of the waveband.

It will be seen that there is a radio frequency choke in parallel with the top half of the volume control R₄.² This has no practical effect on the r.f. signal but it means that the a.f. voltage appearing between the moving arm and the bottom end of the volume control track is directly across the base-emitter junction of TR₁. As R₄ is turned back to reduce reaction the a.f. load R₂ is effectively reduced in value until it is virtually nil when R₄ is at the minimum position. Thus, the arrangement in Fig. 2 results in a single knob which controls both audio frequency amplification and reaction.

A circuit built up as in Fig. 2 will work, but R₄ will have to be re-adjusted for different frequencies and there is a strong possibility that, with efficient transistors and careful layout, oscillation will start at a setting of R₄ which will sufficiently lower the effective value of R₂

² A small 2.5mH choke should be adequate here.—EDITOR.

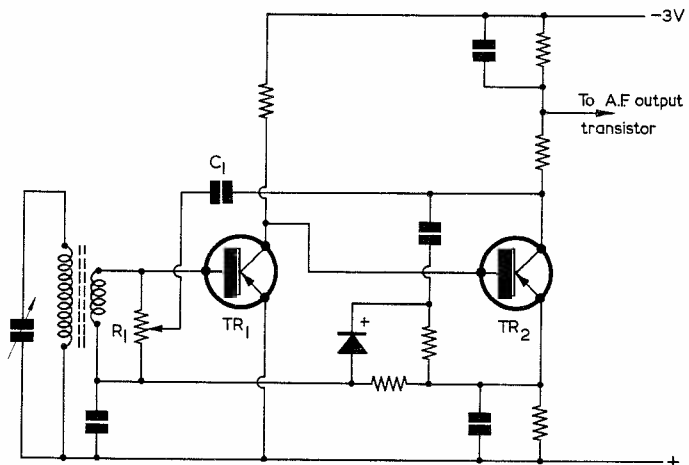

Fig. 1. In this circuit, reaction is obtained by tapping from the collector load a small amount of r.f. and feeding this back through C₁ to the tuned circuit

¹ The "Pocket 4" transistor radio kit is designed by Electronic Precision Equipment Ltd., and is available from that company at 66 Grove Road, Eastbourne.—EDITOR.

to reduce the maximum audio frequency amplification obtainable. It is likely that, at the extreme high frequency end of the range, reaction will come in at a very low setting of R_4 because of unwanted coupling through stray capacitances. It is necessary to arrange that oscillation does not start until R_4 is set to at least the half-way position where it has little effect on the value of R_2 .

A Second Potentiometer

In Fig. 3 a second potentiometer, R_5 , is included. This component can be of the pre-set variety. If, for the time being, only the part of R_5 between points A and B is considered, it will be seen to form a variable resistor, in series with R_6 and C_3 , across the tuned circuit. Up to a point the greater the damping provided by R_5 the more constant will be the setting of the reaction control, which will, of course, have to be turned more and more towards its maximum position in order to produce oscillation. This is just what is needed, as noted earlier, to ensure a satisfactory low frequency load. However, before a position of R_5 is found which will provide sufficient damping to result in an absolutely constant position of R_4 for all frequencies, it will probably be found that oscillation cannot be obtained even at a maximum setting of R_4 . To deal with this the top end, point C of R_5 is joined to the slider of the volume control, R_4 . As a result, a small proportion of the radio frequency signal will pass from the negative end of the diode through R_1 and the top half of R_5 , through R_6 and C_3 , to the tuned circuit. This variable resistor can be adjusted so as to damp the tuned circuit such that it is necessary to turn up the volume control R_4 . R_6 is included solely to increase the effective range of R_5 , and C_3 is necessary to avoid upsetting the bias voltage on the base of TR_1 . C_3 has a value which makes the damping slightly less effective at the lower frequency end of the tuning range, where there are already losses due to a less favourable L/C ratio for the tuned circuit. If R_5 is wired into the circuit (the end C is being left unconnected for the time being) it will be found, after suitable adjustment, that the heavy damping across the tuned circuit will tend to swamp the various factors which cause different efficiencies at different settings of the tuning capacitor, thus bringing about a far more constant setting of R_4 for all frequencies. This radio frequency signal will increase reaction³ and it will now be

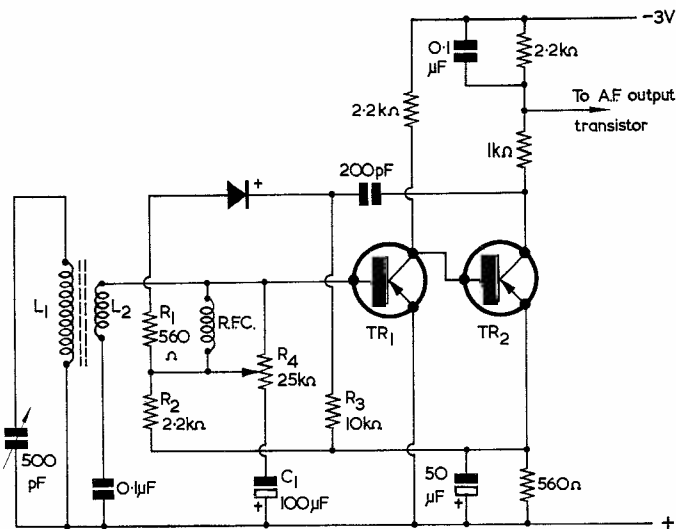

Fig. 2. In this circuit, C_1 has been omitted, R_3 is the r.f. diode load and R_2 the a.f. load

found possible to adjust R_5 once and for all to a setting which produces maximum sensitivity at all except the highest frequencies in the medium waveband for one constant setting of the combined volume-reaction control R_4 .

Highest Frequencies

The highest frequencies in the

³ Provided the tuned and coupling windings on the ferrite frame have the requisite phase relationship.—EDITOR.

band are dealt with by C_2 , the 50pF pre-set capacitor appearing in Fig. 3. This is adjusted so that oscillation at this extreme end of the range is just prevented at the setting of R_5 which has been found suitable for the rest of the range. A little final juggling between R_5 and C_2 will then produce the overall result which is aimed for—a constant maximum setting of R_4 for the whole range. As a general rule this setting is likely to be between half

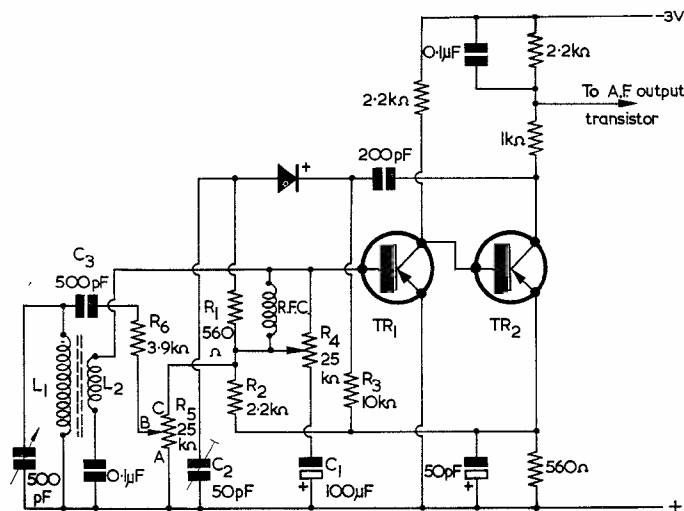

Fig. 3. A second potentiometer, R_5 , is included here and this may be of the pre-set type. Adjustment of the potentiometer is described in the text

and three-quarters "on" from zero, using a volume control with a log track.

Fig. 3 shows optimum values for all components when used in conjunction with top grade surface

barrier transistors. Care should be taken in the layout to prevent unwanted capacitance effects, particularly between the emitter of TR₂ and earth, and between the emitter of TR₂ and the base of TR₁.

Provided these points are carefully observed, it is possible to produce a simple set which behaves in a similar way to a superhet but with far fewer components and with less complication in setting up.



understanding radio



The twenty-eighth in a series of articles which, starting from first principles, describes the basic theory and practice of radio

part 28

By W. G. MORLEY

IN LAST MONTH'S CONTRIBUTION WE DEALT WITH i.f. transformers designed to operate at frequencies within the range 455 to 480 kc/s, the particular components we discussed having adjustable iron dust cores in each winding. We shall now carry on to some further aspects of the i.f. transformer.

Transistor I.F. Transformers

I.F. transformers are employed in transistor radio receivers in just the same manner as occurs in valve receivers. However, for reasons which will later become apparent when we come to consider transistor operation, both the primary and the secondary of the transformer connect to circuits which have relatively low impedances.¹ If either of the tuned windings were connected directly to the low impedance offered by the external circuit it would become heavily damped, and the selectivity offered by the i.f. transformer would be excessively degraded. The solution consists of connecting both the input and output circuits to sections of the tuned windings, as shown in Fig. 172. Each windings then functions as an autotransformer and offers the impedance transformation² needed to match the dynamic resistance of the tuned circuit to the low impedances of the input and output circuits.

There is an alternative type of i.f. transformer employed in transistor receivers which should, for the sake of completeness, also be considered at this stage. This transformer employs a single tuned winding and a coupling winding, as in Fig. 173. As with the transformer of Fig. 172, the input signal is applied to a section of the tuned winding, whilst the coupling winding is connected to the output circuit. The coupling winding has fewer turns than the tuned winding, thereby providing the impedance transformation necessitated by the low impedance output circuit.

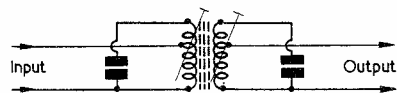

Fig. 172. In transistor receivers, i.f. transformers connect to input and output circuits having relatively low impedances. Matching to these impedances is achieved by tapping into the tuned windings

The transformer of Fig. 172 may be assembled with both coils on a common former, as in Fig. 169, but it is much more common to use two formers mounted parallel to each other, as in Fig. 174. It will be noted that this is basically the same construction as was used in the transformer illustrated in

¹ The terms "primary" and "secondary" apply to the appropriate windings of an i.f. transformer in the same manner as with any other transformer.

² See "Understanding Radio" part 23, July 1963 issue.

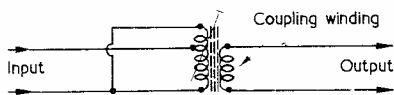

Fig. 173. An alternative type of transistor i.f. transformer has one tuned winding only

Fig. 171.³ The transformer of Fig. 173 is normally provided with a pot core.

When transistor radio receivers were first manufactured in this country, the transformer type shown in Fig. 173 was used much more frequently than that of Fig. 172. In more recent receivers the transformer of Fig. 172 tends, however, to be superseding the single tuned winding component.

Capacitor-tuned I.F. Transformers

An alternative form of i.f. transformer for valve receivers, and one which was extremely common up to the 1950's, is illustrated in Fig. 175. This transformer does not employ iron dust cores, and alignment is carried out by adjusting compression trimmers mounted at the top of the assembly. The trimmers usually appear in a composite ceramic moulding, and are adjusted through two holes in the top of the screening can. In transformers intended for domestic radio receivers the assembly was normally made as inexpensive as possible, and a not uncommon construction consisted of employing a round wooden dowel or cylinder as the coil former, the trimmer moulding and insulated base plate each being secured by a single wood screw driven into the end of the wood.

The capacitor-tuned i.f. transformer suffered from the disadvantage that its trimmers tended to drift slightly with time. When reliable and inexpensive iron dust cores became available, the capacitor-tuned transformer was ousted by the cheaper and more stable designs we have already considered.

Capacitor tuned i.f. transformers intended for military and service requirements did not normally employ compression trimmers. A typical construction would use high-grade air-spaced trimmers, with the result that a high degree of frequency stability could be achieved. Even in these applications,

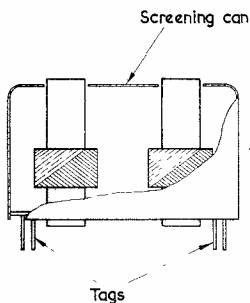

Fig. 174. A typical construction for the transformer of Fig. 172

however, capacitor tuned i.f. transformers have been generally superseded by the iron dust core type.

10.7 Mc/s I.F. Transformers

In radio receivers intended for reception of frequency modulated signals, it is standard practice to employ i.f. transformers which operate at 10.7 Mc/s. A typical example of such a transformer is shown in Fig. 176. As may be noted, the construction is basically the same as that used for the transformer of Fig. 169. Since the transformer operates at a much higher frequency than the types we have so far considered, its coils require lower inductances. Typically, these lower inductances would be provided by single-layer windings, as illustrated in Fig. 176.

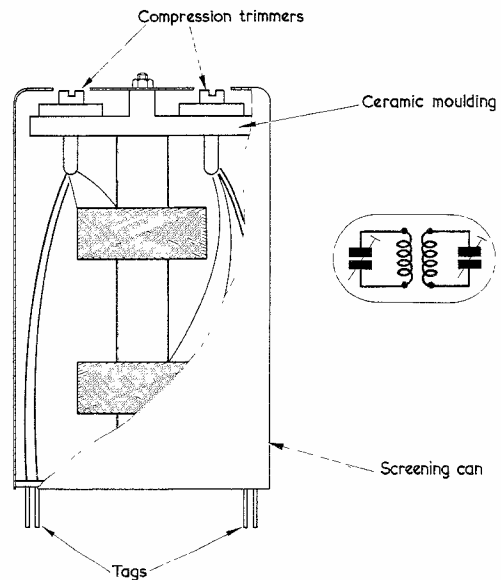

Fig. 175. A capacitor tuned i.f. transformer. The circuit symbol is shown in the inset

I.F. transformers intended for operation at 10.7 Mc/s may also employ the construction of Fig. 174.

An ingenious 10.7 Mc/s design⁴ is shown in Fig. 177. In this diagram two tuned windings, each with an iron dust core, are mounted parallel to each other, a blank former being positioned between them. The two coils may be set to resonate at 10.7 Mc/s by means of their dust cores, after which the mutual inductance between them can be varied by adjusting the position of a third core in the central former. When the central core is at the top of its former (i.e. furthest away from the windings) the coupling is below critical level. As the central core approaches the tuned windings it increases their mutual inductance, causing the transformer to

³ Figs. 169 and 171 were published last month.

⁴ Due to Wireless Telephone Co. Ltd.

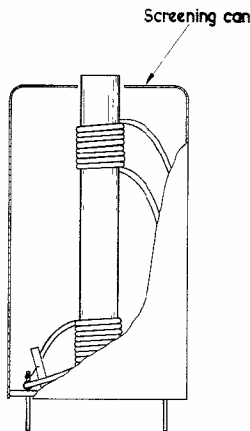

Fig. 176. I.F. transformers for operation at 10.7 Mc/s have the same construction as types intended for operation around 470 kc/s. The higher working frequency results in the use of single layer windings instead of wave-wound coils

pass through critical coupling to over-coupling. The assembly is therefore capable of being set to provide any degree of coupling within its range.

It is possible for radio receivers to have intermediate frequencies other than at 10.7 Mc/s or 455 to 480 kc/s. In general, the associated i.f. transformers would have constructions of the same basic types as those we have examined, the major difference being given by different winding inductances only.

Band Pass Circuits

A *band pass* circuit is provided whenever two resonant circuits are coupled together to provide a composite frequency response curve which allows a band of frequencies to pass. It is rather more usual to refer to the combination as a *band pass filter*, since it acts as a "filter" in allowing the selected band of frequencies to be passed, in preference to others outside the band. The i.f. trans-

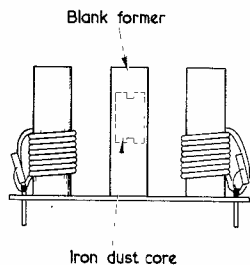

Fig. 177. A 10.7 Mc/s i.f. transformer assembly which enables mutual inductance to be varied. A third iron dust core, shown in dotted line, is fitted to the blank former, and it offers maximum mutual inductance when it is at the lower end of this former. The screening can is not illustrated here

formers we have already dealt with may be described as band pass filters. The term "band pass" merely refers to the fact that a specific band of frequencies is passed and it can be applied to tuned circuits which are under-coupled, critically coupled or over-coupled. There is, nevertheless, a tendency amongst engineers to apply the term to over-coupled combinations only, even though this usage is not entirely accurate.

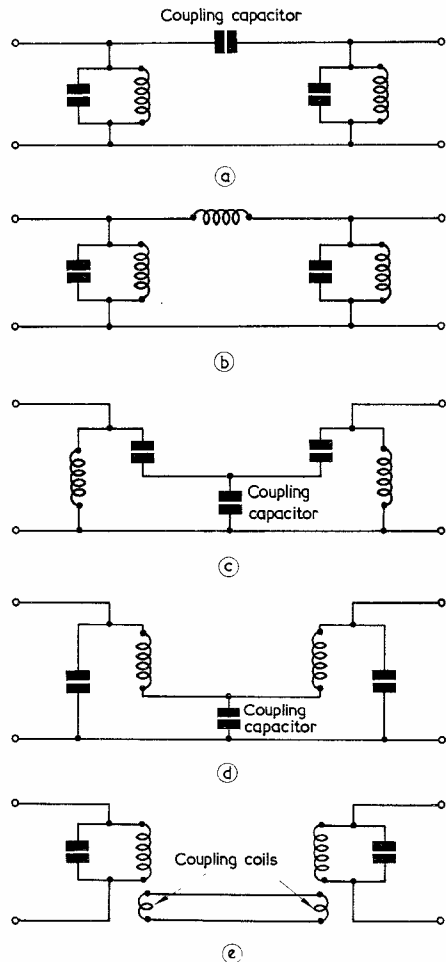

Fig. 178. Some examples of band pass filters. That at (a) employs top capacitance coupling whilst, in (b) the coupling capacitor is replaced by an inductor. Bottom capacitance coupling is used in both (c) and (d), and link coupling in (e)

In the i.f. transformers we have considered so far, the coupling between the two resonant circuits is inductive. It is possible to obtain a band pass filter by coupling two tuned circuits together by other means and there are, indeed, quite a number of coupling techniques which can be employed to achieve this end. A typical example is illustrated

in Fig. 178 (a), in which two tuned circuits are coupled together by a capacitor. It is assumed here (and in the cases which follow) that there is no coupling between the two coils due to mutual inductance. If the value of the coupling capacitor is low the response of the filter will consist of the single peak given by under-coupling. As the value of the coupling capacitor is increased, the filter will pass through critical coupling into the over-coupled state. Thus, increasing the value of the capacitor has the same effect as increasing the inductive coupling of the filters we have previously discussed. An alternative to Fig. 178 (a) is shown in Fig. 178 (b), wherein coupling between the two tuned circuits is provided by an inductor. The filter then passes from under-coupling, through critical coupling, to over-coupling as the value of the inductor decreases.

Another band pass filter circuit is shown in Fig. 178 (c). In this diagram the two tuned circuits share a single capacitor, which thereby provides the requisite coupling. Coupling increases as the value of the common capacitor decreases. Another version of this type of coupling is shown in Fig. 178 (d), in which the common capacitor appears in series with the coils. Again, coupling increases as capacitor value decreases. Both Figs. 178 (c) and (d) could be modified by replacing the common capacitor with a common inductor, whereupon coupling would increase as the value of the inductor increased.

An interesting circuit is shown in Fig. 178 (e). In this diagram each tuned circuit is provided with a coupling coil having a much lower number of turns than the tuned winding. Because of the step-down ratio, the impedances at the terminals of the coupling coils are low, and they may be connected together by relatively long wires without the introduction of excessive losses. The circuit enables a band pass filter to be provided even when the two tuned circuits have to be positioned some distance away from each other.

The band pass filter shown in Fig. 178 (a) represents an example of *top capacitance coupling*, and this type of coupling has been occasionally employed for i.f. transformers in domestic radio receivers instead of the more usual inductive coupling we have examined. The circuits shown in Figs. 178 (c) and (d) represent *bottom capacitance coupling*, whilst that in Fig. 178 (e) is an example of *link coupling*. Apart from the circuit employing top capacitance coupling, the band pass filters of Fig. 178 do not appear frequently in simple radio receiver designs, although they are very often employed in television receivers.

It is possible to make up band pass filters using alternative configurations to those given in Fig. 178. The circuits shown here are, however, representative of those most likely to be encountered, and they readily illustrate the basic principles involved.

Absorption Effects

An aspect of coupled tuned circuits which we have not considered yet is provided by *absorption*. The effect of absorption may be illustrated with the

aid of the example shown in Fig. 179. In this diagram we have a tuned circuit, L_1C_1 , across which appear voltages at its resonant frequency. Brought close to this tuned circuit, so that an inductive coupling appears between the two coils, is a tuned circuit, L_2C_2 . L_2C_2 will extract energy from L_1C_1 at the resonant frequency of L_2C_2 . In the present instance, such absorption of energy will occur when L_2C_2 is resonant at the same frequency as L_1C_1 , and may result in a reduction of the voltage appearing across L_1C_1 .

Absorption is of value in radio work because, if one circuit passes a wide band of frequencies, an absorbing circuit (consisting of a parallel tuned circuit on its own) may absorb energy at a single frequency within that band, thereby modifying the overall response. The frequency at which absorption takes place is that at which the absorbing circuit is resonant.

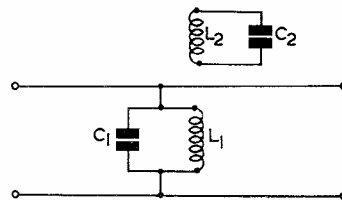

Fig. 179. When the coil of tuned circuit L_2C_2 couples inductively to that of L_1C_1 , energy may be absorbed at the resonant frequency of L_2C_2

The absorption effect may also be employed for finding the resonant frequency of a tuned circuit without the necessity for making an actual connection. The two coils of two tuned circuits are brought close together in order to allow an inductive coupling to appear between them. If one tuned circuit is adjusted for maximum absorption due to the other tuned circuit, they are both resonant at the same frequency. The resonant frequency of the second tuned circuit may then be determined from a scale fitted to the variable element of the first.

Screening-Inductive

In an earlier issue⁵ we saw that inductive couplings between iron-cored transformers may be reduced by placing between them a shield made from a sheet of high permeability material. Usually, one of the iron-cored components is fitted in a housing made from the high permeability material. We have noted also that i.f. transformers are similarly enclosed, these components being housed in screening cans.

The function of the i.f. transformer screening can is to prevent unwanted inductive and capacitive couplings taking place between the transformer and other components mounted close to it. We shall consider first of all the manner in which inductive couplings are prevented.

⁵ "Understanding Radio", part 24, August 1963 issue.

The magnetic field about an i.f. transformer changes at the frequency to which the transformer is tuned. If the field impinges on a conducting metal sheet it sets up currents which, in their turn, produce opposing fields. In consequence, the field can only enter the conducting medium for a small distance before the opposing fields cause it to be almost completely cancelled out. It follows from this that the field about an i.f. transformer may be constrained by enclosing it in a housing which is made of conducting material.⁶

An i.f. transformer screening can function in a different manner from the magnetic shield provided with low frequency iron-cored components. In the latter, magnetic fields changing at low frequency flow along a high permeability shield rather than through the lower permeability air. In the case of the i.f. transformer screening can, the higher frequency magnetic fields are prevented from passing through the screening material because of the opposing fields which they generate. As a result,

⁶ As we shall see next month, the same comment applies to all coils operating at radio frequencies.

the major requirement of the material used for the i.f. screening can is not that it should have a high permeability, but that it should be a good conductor. There is no necessity to use a metal having magnetic properties at all and, in practice, i.f. transformer screening cans are normally made of aluminium, or of a similar metal which is easy to fabricate as well as being a good conductor. I.F. transformer screening cans are sometimes made from mild steel sheet, but such material is used only because of its conducting, and not because of its magnetic, properties.

Next Month

In next month's issue we shall carry on to capacitive screening.

Correction

It is regretted that, in "Understanding Radio" part 26 (published in the October issue), there is an error in Figs. 160 (b) and 161 (b). In these diagrams the positions of the switch across the long wave tuned winding are incorrectly designated. The switch should short-circuit the long wave tuned winding when "medium waves" is selected.

TRADE REVIEW . . .

The "Transmatch" Transistor Pre-amplifier, Model TMU-1

The "Transmatch" transistor preamplifier has been introduced by Electroman (Poldew Ltd.), Mitcham, Surrey, to provide a matching and amplifying unit suitable for coupling low impedance signals to the high input impedances of valve amplifiers. It is recommended for use with guitars, magnetic gramophone pick-ups, moving coil and ribbon microphones, and any other devices offering a relatively low signal level at an impedance in the range of around 25Ω to 1kΩ. The output from the "Transmatch" unit may be connected to any valve amplifier having an input impedance of 100kΩ or more.

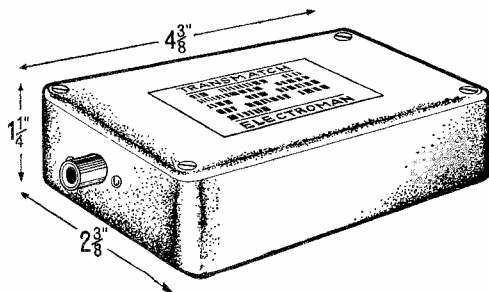

The "Transmatch" unit is fitted with a jack and a flush coaxial socket. The output from the low impedance device should be connected to the requisite jack plug, whilst the input to the following amplifier is taken from the coaxial socket. Inserting the jack plug automatically switches on the internal PP3 9 volt battery in the unit, this supplying power to a single-transistor amplifier operating in the earthed emitter configuration. The amplifier has component values suitable for the impedance transformation function, and it is fully stabilised.

The response of the unit is flat from 40 c/s to 20 kc/s, with negligible distortion at all normal input levels. Since it has its own battery supply and is completely self-contained, there is no possibility of its introducing hum. Naturally, all leads to the unit should be screened, and it is recommended that the associated valve amplifier be earthed.

The unit is housed in a very robust die-cast metal case measuring 4 3/8 x 2 3/8 x 1 1/2 in, and having an attractive grey hammer finish. The input jack appears at one end of the case and the output coaxial socket at the other, thereby allowing the unit to be inserted at any convenient point in the cable run to the amplifier. The outer connectors of both input and output sockets are common to the die-cast case, which therefore provides unbroken screening over the complete length of the cable run.

The retail price of the "Transmatch" preamplifier Model TMU-1 is £3 10s. 6d., and it is available from Home Radio (Mitcham) Ltd.

NEWS AND COMMENT . .

Echo-free

Those readers who have used public address systems in large buildings will be well aware of the problems of audibility, quality and reverberation. A new type of public address system is to be installed in St. Paul's Cathedral which, it is claimed, will overcome the problems of reverberation which are very considerable in such an extensive building.

In St. Paul's, a sound requires 3/10ths of a second to travel the length of the building, and ten seconds to die out completely. With a public address system of the usual design, some sounds would be delayed more than others and echoes would result.

The system will circumvent these problems by transcribing all sounds first on a tape-recorder and then feeding them to the loudspeakers after suitable small delays. The delayed sounds from the loudspeakers will therefore reach the congregation at the same time as the sounds directly from the pulpit, all sound waves heard will be "in step," and echoes will be prevented.

The system will be installed by a British Affiliate of the International Telephone and Telegraph Corporation.

Hospital Communications

Ward 6 of the Broomfield Hospital, near Chelmsford, has been equipped throughout with a Mimco sound system providing intercommunication facilities between patients and nurses, as well as a choice of two entertainment programmes. Each of the fifty-three beds has its own flush-mounted wall control panel complete with the patient's remote control bed unit, from which a call can be made to the duty nurse at any time.

The system, designed and installed by The Marconi International Marine Co. Ltd., makes it as easy as possible for the patient to use it, even if he is incapable of sitting up in bed. A patient requiring the attention of a nurse presses a "call" button on the remote control bed unit. This action initiates a visual and audible call signal at all nurse "answer-back" positions, which will continue until answered by a member of the staff.

When the call is answered a voice-operated relay comes into operation enabling the patient and nurse to carry on a two-way conversation without the need for either to press any switches. The patient does not have to pick up a microphone or sit up or turn round to speak, as the microphone used by the patient is, in fact, also the loudspeaker of the remote bed unit. This is sufficiently sensitive to transmit even a weak voice, so that the patient merely has to talk "into the air" to be heard by the nurse.

Expanding Frontiers

Dr. R. G. C. Williams, Chief Engineer of Philips Electrical Industries, had some worthwhile things to say about the expansion of electronics in his recent Inaugural Address as Chairman of the Electronics Division of the Institution of Electrical Engineers.

We summarise some of his address:

Technological Explosion.

"Since the dawn of civilisation, progress has been marked by occasional spectacular inventions, which have enabled mankind to take a great leap forward—what engineers call a 'million to one' gain. A classic example is printing, which enabled millions to be put into communication with the minds of the past and present.

One of the characteristics of electronics is its disturbing capability of originating discoveries of the 'million to one' level. Another is the way in which it infiltrates into all the older technologies and invades their boundaries."

The Laser

"The laser—'light amplification by stimulated emission of radiation'—came out of the physics field, and is an example of a 'million to one' gain still in the laboratory stage. It makes use of atomic structure itself as a circuit element and operates by stimulating electrons to move between higher and lower energy levels within the atoms of the material to produce coherent radiation of radio wave type in the infra-red and visible band of the electromagnetic spectrum.

Important effects stem from coherent radiation at these fre-

quencies. There is the possibility of modulating it as we do a radio wave to superimpose communication information. At these extraordinarily high frequencies an enormous number of communication channels may be accommodated and in theory within the boundaries of the visible spectrum alone over 30 million different television signals could be carried, or in telephone terms one half of all the people in the world could speak to the other half at the same time."

Television

"Television has come on us so quickly that I think we have failed to realise that it provides in audiences a 'million to one' gain over the size previously possible and popular programmes regularly reach audiences of 20 million. But television also provides a means of giving to all men and women, young and old, an opportunity of improving their knowledge by making educational programmes available to them in their homes."

Bird Dispersal

An unusual use of sound reproduction is the method used at some airports, such as Prestwick, Heath Row, Gatwick, etc., in helping to disperse birds from the runways when aircraft are taking off and landing.

Sappho equipment, produced by Trix Electronics Ltd., is used. Through audio equipment, bird cries are broadcast, those chosen being mostly likely to cause the birds to fly away.

Contest

On page 350 of this issue will be found details of our Christmas Castaway Contest. This is the first time we have run a competition and we think it may provide an interesting challenge to the ingenuity of many of our readers.

Even if you do not send in an entry, although we hope you will, the competition may provide you with some amusement as a change from filling up pool coupons and the normal activities popular at this time of the year.

There is no entrance fee, entries must be received by first post on Monday, 20th January.

Simple Electronic Rev. Counter

By D. F. Warren

An experimental tachometer circuit which has the advantages of low cost and considerable simplicity

THE IDEA FOR THIS UNIT CAME from an article in the November 1961 issue which described the Oxford Tachometer.* In this design a capacitor and a resistor form a frequency-sensitive potential divider. The Oxford Tachometer attains remarkable accuracy, but may tend to be somewhat expensive for some constructors' pockets.

An Alternative Circuit

By using a different circuit after the CR chain it is possible to make an instrument which is sufficiently accurate for most purposes and which is much cheaper. Indeed, most of the parts are probably already in the "junk box".

From Fig. 1 it will be seen that the reactance of C_1 reduces as the input frequency is increased, with the result that the voltage developed across R_1 and applied to D_1 for rectification is proportional to the frequency of input pulses or engine

* Hugh Guy, "The Oxford Tachometer", *The Radio Constructor*, November 1961.

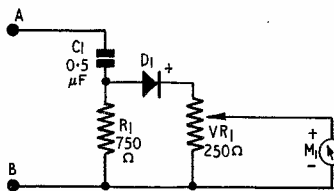

Fig. 1. The circuit of the simple electronic rev. counter. Terminal A connects to the coil/contact breaker junction whilst terminal B is connected to the battery end of the coil (negative with positive earth systems). The diode is an OA73 or similar type. Alternative methods of connection are referred to in the text

speed. Part of the d.c. voltage across VR_1 is then used to operate the meter. This can be either a milliammeter or a voltmeter having a scale of 0-1 or 0-10, so that it may indicate up to 10,000 r.p.m. when the reading is suitably multiplied. The meter used in the prototype had an f.s.d. of 1mA and an internal resistance of 60Ω. The writer would stress, however, that any reasonably sensitive instrument, either voltmeter or milliammeter, can be used, and that he considers this to be an advantage with the present circuit.

Since the CR chain will be sensitive to variations of input amplitude and, to a lesser extent, to changes of waveform, it is not possible to set up the unit from a signal generator. The easiest method of calibration is to find out from the car handbook how fast the car will travel at 1,000 r.p.m. and in top gear, then drive at or three times this speed and set VR_1 for a correct reading in M_1 . The prototype was installed in a Mini which travels at 14.9 m.p.h. per 1,000 r.p.m. The car was driven at just under 30 m.p.h., and VR_1 set so that M_1 indicated 2,000 r.p.m.

This method of calibration is, of course, only as accurate as the car's

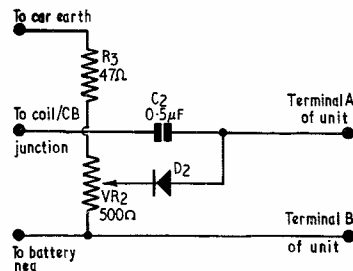

Fig. 2. A limiter circuit which may improve performance in some instances. The diode is an OA73 or similar type

speedometer. If greater accuracy is required the car can be taken to a garage having Crypton "Tuner" equipment, or similar instruments, whereupon the rev. counter may be set up accordingly.

Connecting the Engine

There are four methods of connecting the unit to the engine. Terminals A and B can be connected across the coil, or reversed; or between coil and chassis, or reversed. All these methods work, but the best results were obtained with the connections indicated in Fig. 1.

If the unit gives non-linear or unreliable readings due to the car battery or ignition system being in poor health, a simple pulse limiter may be added to give constant amplitude pulses. (See Fig. 2.) This circuit applies for positive earth systems. With negative earth systems, the diode should be reversed. VR_2 should be set so that its wiper is as near the R_3 end of the track as possible, consistent with good results.

Editor's Note: Figs. 1 and 2 specify an OA73 or similar. The OA73 has a p.i.v. of 30 volts only, and it may be preferable to use, say, the OA71 (p.i.v.=90 volts at 50°C) or the OA81 (p.i.v.=100 volts at 75°C).

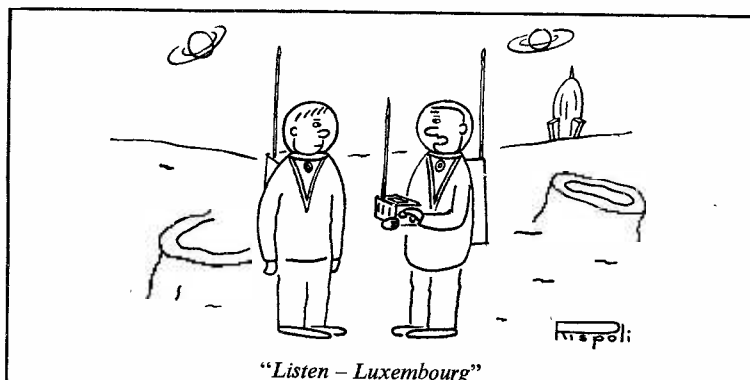

TRANSISTORISED TELEVISION CIRCUITS

PART 2. By Gordon J. King,
Assoc.Brit.I.R.E., M.T.S., M.I.P.R.E.

In the first part of this series, which was published last month, our contributor introduced the subject of transistors in television receivers and dealt, in particular, with transistorised tuner units. This second article describes the sound and vision i.f. amplifiers

The I.F. Stages

THE SOUND AND VISION I.F. STAGES OF THE TRANSISTORISED t.v. receiver may either be fed direct from a split output at the tuner or via one or two stages common to both sound and vision signals. It will be recalled that either technique is adopted in valve receivers, though of recent years the common i.f. stage arrangement has been favoured, the output of this being split to provide the sound and vision channels.

In the Perdio transistorised television receiver, for example, the tuner feeds two common stages, while in the Pye Model TT1 the sound and vision channels are fed direct from the tuner output, there being no common stage.

The use of one or more common stages means that subsequent sound and vision i.f. stages need have less relative gain than those in sets where the stages are individually fed direct from the tuner. There are also times when it can be easier to apply vision a.g.c. to a common stage than to a narrower bandwidth vision i.f. stage. A.G.C. is, of course, also applied to the tuner, as was explained last month. Sound a.g.c. is usually applied separately, as in an ordinary radio set.

Sound I.F. Amplifier

The sound i.f. amplifier and detector of the Pye Model TT1 is shown in Fig. 4. This has three fairly straightforward grounded-emitter neutralised stages. As the circuit impedances are high, each stage is individually neutralised, this being taken care of by C_7 , C_{12} and C_{17} , and the associated winding on each i.f. transformer. The asterisk by the side of these capacitors indicates that the value may change in production. Extreme care must be taken to see that the "fitted value" is always used in the event of the replacement of a neutralising capacitor during servicing.

Sound I.F. Sensitivity

The overall gain of the sound i.f. channel in the Pye receiver is around 62dB, meaning that a $250\mu\text{V}$ signal at the sound i.f. (38.15 Mc/s) applied to the base of TR_4 should give approximately 300mV at the sound detector diode.

Successive sensitivities for 300mV at the sound detector with the i.f. signal applied in turn to the base of TR_5 and TR_6 are 1.25mV and 8mV respectively. These figures can be useful as a guide in determining the location of a fault in the sound stages.

A figure of between 50 and 65dB of overall sound i.f. channel gain is commonplace. The gain may, of course, be made up in part by the gain of the common stage or stages plus the gain of the sound i.f. amplifier proper. In the Perdio set, for example, the sound i.f. amplifier gives about 26dB of gain, the remainder being contributed by the two common stages.

Deviations

Most sound i.f. stages adopt the grounded-emitter configuration. This is somewhat analogous to the grounded-cathode valve circuit, where the signal is applied to the control grid and is developed across the anode load in amplified form. In the transistor instance the signal is applied to the base and developed across the load in the collector circuit.

When we were discussing transistorised tuners, last month, we discovered that the grounded base configuration of the r.f. amplifier, for example, helped with impedance matching from the aerial to the mixer, the impedance undergoing a step-up from emitter to collector. With the grounded-emitter circuit (sometimes called "common emitter", since the emitter in the circuit is arranged to be common to both the collector and base) the impe-

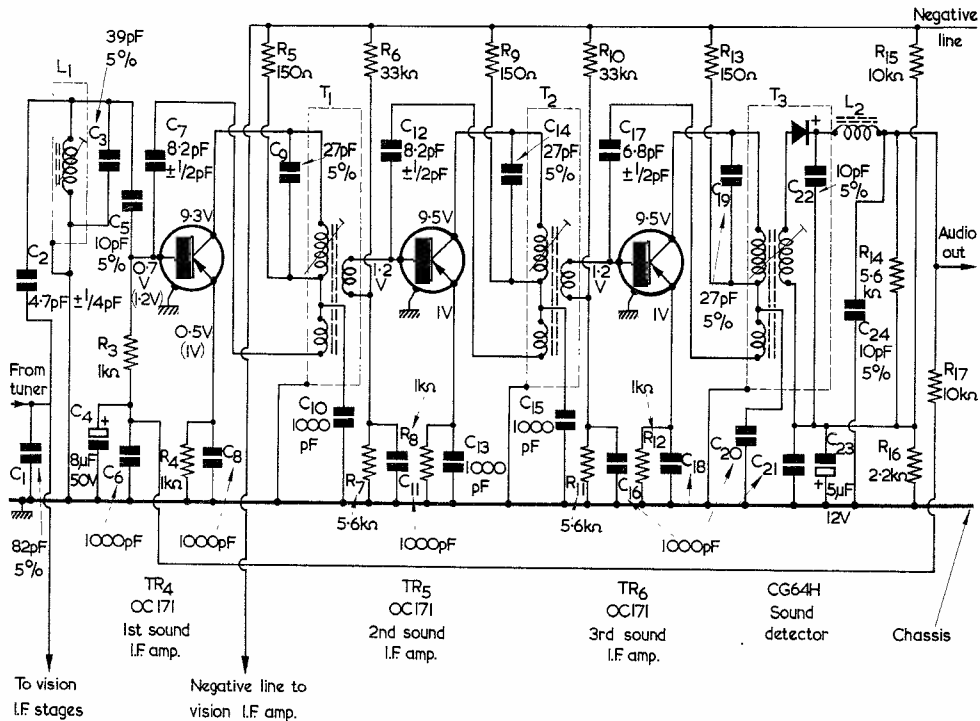

Fig. 4. The sound i.f. amplifier and detector of the Pye Model TT1. Each i.f. amplifier stage is individually neutralised. The overall i.f. gain is approximately 62dB, which means that about 300mV of signal should be present at the sound detector for an input signal of 250 μ V. The asterisks by the side of the neutralising capacitors C₇, C₁₂ and C₁₇ indicate that their values may vary in production, this being necessary to ensure optimum neutralisation

dance at the base is still low (typically 300 to 1,000 Ω) owing to the forward bias across the emitter-base junction of the transistor, while the impedance at the collector is much higher, being about 100k Ω or less.

This means that to secure maximum signal transfer from one stage to the next, the high collector impedance must be "transformed" to a suitable low impedance value to match the base to which it is to couple. This is achieved simply enough by the use of coupling i.f. transformers with the corresponding turns ratio, as in ordinary transistor radio sets.

Looking at Fig. 4, for instance, will show that the collector windings of the i.f. transformers T₁ and T₂ have a greater number of turns than the associated base windings, thereby giving a "step-down" impedance transfer.

It has been mentioned that the third windings on the three i.f. transformers of Fig. 4 are related to the neutralising function in association with the capacitors between the winding and the base of the corresponding transistor. The neutralising components provide negative feedback between the output and input to prevent oscillation in the amplifier. Without neutralisation, the capacitances between collector and base, and base and emitter, may produce positive feedback and hence oscillation.

The negative neutralising feedback just balances the positive feedback and thus ensures stability.

Not all i.f. amplifier stages utilise this mode of neutralisation, however. In the Perdio set, for example, instead of basic neutralising, as described, damping resistors (3.3k Ω) are connected in parallel with the collector windings of the appropriate transformers. These "damp down" the positive feedback and give a high order of stability and relative ease of alignment. They also allow the replacement of transistors without the need for re-balancing the neutralising capacitors. However, with the latest kind of neutralisation, as employed in the Pye set, there are no undue problems as there were in the early experimental days of transistorised television, when the neutralisation and the i.f. tuning interacted so badly that individual adjustment of each parameter was required many times before the alignment was satisfactory.

Bandwidth

In ordinary transistor radio sets the collector is often taken to a tap on the primary winding of the i.f. transformer. The basic reason for this is to ensure optimum selectivity, for the output impedance of a transistor in the common-emitter condition is not as high as the impedance of the primary

tuned circuit of the i.f. transformer at its tuned frequency. The collector is therefore connected to an impedance matching point on the primary winding. This reduces the damping across the tuned circuit and ensures good selectivity.

With television i.f. stages this is not so important, especially in the vision channel where a wide bandwidth is necessary to cater for the high frequency sidebands of the vision signal. In the sound channel, too, the problem is not as critical as on the ordinary broadcast bands, and so an impedance tap is rarely employed.

Even with the "natural" damping caused by the transistor collector impedance, tuning the i.f. transformers for peak response can still produce a too-narrow sound response curve and so aggravate tuning and oscillator drift problems. This, then, makes it necessary to carefully align the sound i.f. channel for both optimum gain and optimum response. The curve in Fig. 5 is representative of the desired sound i.f. response, it being between 600 and 800 kc/s wide at the half-power (-3dB) points. While such a curve may be attainable by simply peaking each i.f. transformer tuning core and then carefully detuning one or two to give the gently curved response top, relying on the plotting of response against frequency, by far the best idea is to use a wobulator and oscilloscope for a visual display of the response characteristics. Visual alignment is rather more important on transistorised television equipment than on valve models.

Also, in common with transistor broadcast receiver practice, only the primaries of the i.f. transformers may be tuned, as in Fig. 4. Despite the untuned secondaries, sufficient gain is obtained from the i.f. channels because the transformer windings are arranged on special ferrite cores which themselves have a high Q value.

Circuit Detail

R_6 , R_7 and R_{10} . R_{11} form potential dividers for setting the base bias of TR_5 and TR_6 respectively. The arrangement here is slightly different so far as the first sound i.f. stage (TR_4) is concerned, as this stage has sound a.g.c. applied to it, fed back from the detector load.

The emitter resistors R_4 , R_8 and R_{12} stabilise the d.c. operation of the stages in accordance with normal transistor techniques. For instance, consider an increase in collector current in TR_5 brought about by increased leakage in the transistor (I'_{co}) as the result of an increase in temperature or some other reason. An increase in collector current produces an increase in emitter current (in the same way as an increase of anode current in a valve produces a corresponding increase of current in the cathode circuit), and thus an increased voltage drop across the emitter resistor R_8 . The voltage at the emitter as a consequence becomes more negative, so reducing the forward base-emitter bias. This reduces the base current and in turn restores the collector current to its original value. To appreciate this explanation it is, of course, necessary to understand that the greater the forward current in the

base-emitter junction, the greater the collector current (within limits). An increase of forward base-emitter current is rather like a decrease of negative (less negative) grid bias on a valve, resulting in a rise of anode current.

Without d.c. stabilisation, leakage current due, say, to a rise in temperature, would cause a rise in collector current which in turn would increase the temperature. This would increase the leakage, and so on, until the transistor failed. The effect is called "thermal runaway".

Detector and A.G.C.

An ordinary germanium diode is generally used as the sound detector, and in Fig. 4 this is fed from a suitable winding on the final sound i.f. transformer T_3 . The detector load is R_{14} , from which the audio signal is extracted.

C_{22} is an effective reservoir capacitor, L_2 the i.f. filter choke and C_{24} the filter capacitor. R_{15} and R_{16} form the base potential divider network for the a.g.c. controlled transistor TR_4 , the d.c. voltage formed across the load R_{14} due to the signal being used as a.g.c. bias for this transistor. Connection from the junction of R_{15} and R_{16} to TR_4 base is made via R_{14} , R_{17} and R_3 .

In the event of zero sound signal TR_4 is thus biased purely by the potential divider effect of R_{15} and R_{16} . When a signal is received the voltage across the load R_{14} goes positive at the L_2 end by an amount depending upon signal strength. This reduces the forward base-emitter bias of TR_4 and consequently reduces its gain, the amount of gain reduction depending upon the rise in signal level input, as with normal a.g.c. systems.

Bypassing

It is usual to bypass the base and emitter circuits to their operating frequencies. The emitter resistors, for example, are bypassed by 1,000pF capacitors, these being adequate to give a low impedance at

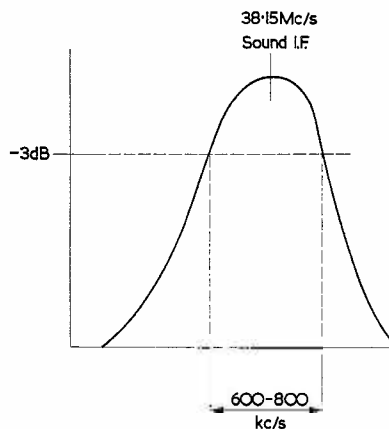

Fig. 5. Typical overall sound i.f. response curve of a transistorised receiver

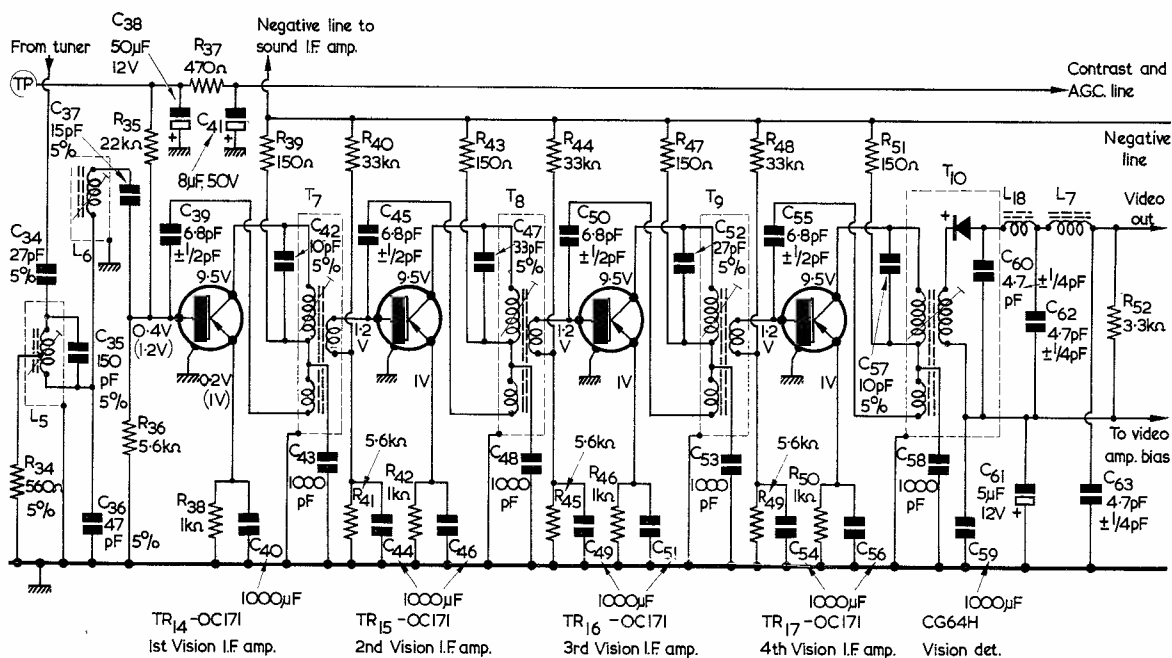

Fig. 6. The vision i.f. amplifier and detector of the Pye Model TT1. Individual neutralising is adopted by means of a third winding on the i.f. transformers closely coupled to the collector winding. A.G.C. and contrast control is achieved by a varying negative voltage derived from the a.g.c. amplifier and applied to the base potential divider of TR₁₄

the sound i.f. The base circuits are similarly bypassed.

The electrolytic capacitor C₂₃ eliminates audio voltages from the detector and a.g.c. feed circuit, with further filtering being carried out by R₁₇ and the second electrolytic capacitor C₄.

Failure of the i.f. bypass capacitors could cause both gain reduction and, in some cases, instability, as in a valve amplifier stage. There may well be a relatively large degree of misalignment due to this trouble also, so if there is a sudden tendency for the i.f. channel of a receiver to lose sensitivity and it appears that retuning may restore the gain, the bypass capacitors should be checked before attempting too much with the i.f. alignment.

Vision I.F. Amplifier

Much of what has been said in connection with the sound i.f. stages applies also to the vision i.f. stages. This is true in particular with respect to circuit detail, including base biasing, d.c. stabilisation, bypassing, and so on. A typical vision i.f. channel and detector is shown in Fig. 6. This relates to the Pye TT1, where four grounded-emitter, neutralised stages are employed.

Like the sound i.f. stages, all four transistors are neutralised by an antiphase signal derived, via capacitors, from overwindings tightly coupled to the collector tuned circuits. The capacitors concerned with this operation are each marked with an asterisk in Fig. 6, this signifying, as with Fig. 4, that the value of the capacitor may vary in production.

The 34.65 Mc/s vision i.f. carrier signal is "bottom capacitance" coupled to the first vision i.f. amplifier, TR₁₄, direct from the tuner. Note here that the signal is fed via L₅ which is a "bridged-T" sound i.f. rejector (trap), while L₆ is the input i.f. winding on a separate former and separately screened.

In this circuit the vision channel frequency response is achieved by the use of two high Q and two low Q tuned i.f. coupling transformers in a staggered tuning arrangement, giving the response shown in Fig. 7.

Manual and Automatic Gain Control

The gain of the vision i.f. channel is controlled both manually and automatically by means of a separate negative supply line to the base circuit of TR₁₄ (i.e. to the top arm—R₃₅—of the base potential divider). We shall see later that this negative supply is derived from the collector of the a.g.c. amplifier transistor. As the contrast control is in the emitter circuit of the a.g.c. amplifier transistor, its adjustment varies TR₁₄ bias and hence the gain of the i.f. amplifier channel. The voltage on this line also varies automatically to suit the signal conditions; the stronger the signal, the less the negative voltage and the smaller the gain of the vision channel. C₃₈, C₄₁ and R₃₇ serve to filter the a.g.c. and contrast control line. The line is terminated at a test point (TP) to facilitate alignment and general testing.

Sensitivity

The sensitivity of the four-stage vision channel

of Fig. 6 at 36 Mc/s is such that 300mV peak-to-peak signal occurs at the vision detector when a $30\mu\text{V}$ signal modulated with 50% a.m. at 1 kc/s is applied to the base of TR₁₄ (i.e. about 80dB gain). Sensitivities at the base of TR₁₅, TR₁₆ and TR₁₇ for the same output and under the same signal conditions are $150\mu\text{V}$, 1mV and 6mV respectively.

Deviations have already been noted, in that resistive damping may be employed instead of neutralising (as in the Perdio "Portarama"). The number of stages employed in the i.f. stages varies between receivers, as in valve models. The Pye receiver, as we have seen, uses three in the sound channel and four in the vision channel, while the Perdio set uses a total of four transistor stages in the vision plus the sound channels, two being common to both sound and vision and then one for sound and one for vision.

In the Perdio receiver the a.g.c. and manual contrast control is effected on the first common stage as well as on the tuner, with delay on the latter as mentioned in Part 1 of this series.

The final vision i.f. amplifier transistor feeds the vision detector via the i.f. transformer T₁₀, the load being R₅₂, the reservoir capacitor C₆₀, the filter choke L₁₃, the filter capacitor C₆₂, and the Band I i.f. choke L₇.

The value of detector load resistor is somewhat

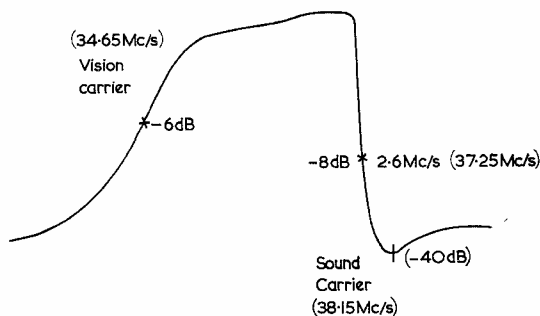

Fig. 7. Response shaping of the vision i.f. channel of the Pye TT1 is achieved by the use of two high Q and two low Q tuned i.f. coupling transformers. The response when the alignment is correct is shown in this diagram

influenced by the design of the following video amplifier stage, but it is desirable to keep the value as low as possible to ensure the best possible response characteristics.

Next month we shall deal with the video amplifier and the audio stages, and shall see, also, how the vision a.g.c. bias is derived.

(To be continued)

Beam Deflection Tube

Type 7360

THE RCA 7360 VALVE IS A MINIATURE BEAM deflection tube intended for use as a balanced modulator, balanced mixer or product detector. The tube will, however, be very useful in numerous other applications which require a tube providing an output current which is proportional to the instantaneous product of two separate input waveforms. It has a B9A base and can operate at frequencies up to about 100 Mc/s.

The symbol for this unusual type of tube is shown in the accompanying diagram. The valve has a cathode, control grid (g_1) and screen grid (g_2) which perform the same functions as in conventional tubes. After the screen grid, the tube is divided into two sections, each of which contains a deflection electrode and an anode. The total beam current is controlled by the potentials of g_1 and g_2 relative to the cathode, as in a normal valve, but the portion of the total beam current collected by each individual anode is determined by the difference in potential of the two deflecting electrodes. In the balanced conditions, the two anode currents are equal.

The action of the 7360 tube may be compared with that of a multi-grid tube such as a heptode, which can also be used in modulators and mixers.

In a multi-grid tube the third grid returns a portion of the beam current to the screen grid; this returned current can affect the space charge region so that a true product of the voltages at the first and third grids is not obtained. In addition the returned current may cause undesired coupling and alter the input impedance at the grids. The 7360 tube does not suffer from these defects.

Operating Conditions

The maximum deflection transconductance is obtained from the tube if it is operated with a mean

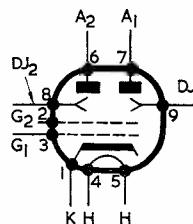

DJ = Deflection electrode

Pin connections for the 7360 tube

deflecting electrode potential of about +25 volts with respect to the cathode. A deflecting electrode potential of 12 volts peak-to-peak will then switch the beam almost completely from one anode to the other at a control grid bias of -2 volts. If linearity is of prime importance, the deflection electrode potential should be about 8 volts peak-to-peak.

The tube is sensitive to magnetic fields and should therefore be placed well away from transformers, smoothing chokes, electric motors, etc. It may be advisable to screen the tube magnetically.

Uses

The unique features of the 7360 tube enable simpler balanced modulator and balanced mixer circuits to be constructed than is possible with conventional tubes. Such circuits are especially useful in single sideband transmitters. In a typical arrangement the audio signal to be transmitted is fed to a self oscillating 7360 balanced modulator circuit. After passing through the s.s.b. filter, the modulated signal passes to a second 7360 tube which is used as a self-oscillating first mixer. It then passes to the second mixer (and v.f.o.) which may also be a self-oscillating 7360 circuit; finally the signal passes to the drive and output stages. The use of the 7360 in such an arrangement eliminates the need for separate oscillator tubes and provides a high gain which usually enables one stage less to be used in the s.s.b. transmitter than would be possible if conventional tubes had been employed.

The degree of balance is usually much better when

the 7360 is employed than when other tubes are used, since any changes that occur in the common cathode, first grid or screen grid circuits of the 7360 will affect both anode currents equally. In addition any unbalanced anode currents will produce differences of anode voltage which will tend to restore the balance. It is thus usually fairly easy to balance out the carrier when the 7360 is used in s.s.b. circuits, and an overall carrier suppression of 60dB below the sideband output can readily be obtained. The distortion is very low.

Circuits for balance modulator and balanced mixer operation are available from the manufacturers of the tube.^{1,2}

An interesting use of the 7360 as a noise silencer tube for communication receivers has also been published.³

References

1. 7360 Beam Deflection Tube Data Sheets.
2. R.C.A. Application Note Number AN-185.
3. "An Effective Noise Silencer" by G. T. Sassoon (G3JZK). *The Short Wave Magazine*, August 1962.

References 1 and 2 are available from R.C.A. Great Britain Ltd., Lincoln Way, Windmill Road, Sunbury-on-Thames, Middlesex.

Editor's Note

We are informed by R.C.A. Great Britain Ltd. that small stocks of 7360 tubes are normally held at Sunbury, and can be delivered within a few days from receipt of order.

Contrast & Castle Effects Records - *Latest Releases*

The latest releases under the Castle Label (45 r.p.m. sound effects records) include three new non-copyright effects discs contained in attractive three-colour glossy sleeves.

All are separately tracked and timed effects and they provide an economical method of obtaining first class material for dubbing on to cine film, tape used for background to slide shows, or for direct use on the stage by amateur dramatic societies, schools and colleges, etc.

MF3-3 Horses and Domestic Animals. Walking, trotting, jumping, galloping, different surfaces. Cows, pigs, foxhounds, hunting horns and calls, etc.

EF3-1 Electronic Music and Sounds. Electronic music (two compositions on side 1) 13 electronic sound effects, including space ships on side 2.

HMX-1 Haunted Houses and Mystery Sounds. Electronic mystery music, authentic storm, spook and ghost sounds (electronic). Creaks, footsteps, shrieks, etc., (natural).

Current issues include the following:

TFX-1 British Railways. Complete disc of British Railways sounds.

AFX-1 Sounds of wild animals. Rattlesnakes, lions, elephants, vipers, chimpanzees, etc.

MF3-1. Lions roaring, aircraft landing, road drills, cell doors and locks, storm at sea, police cars and trains.

MF3-2. American police cars, orchestras tuning, applause, car crash, breaking glass and tube trains.

Because of their excellent quality of recording and reproduction, and also because they have the added attraction of being free from annoying copyright restrictions as to dubbing and use, these records have proved an instant success. Manufactured by Rapid Recording Service of London, on behalf of Recorder Tuition Ltd., they may be obtained, price 7s. 6d. each plus 6d. postage and packing, inclusive of purchase tax, direct from Recorded Tuition Ltd., 174/176 Maybank Road, South Woodford, London, E.18. Telephone BUCKhurst 9315

IN YOUR WORKSHOP



This month we join Smithy the Serviceman and his able assistant Dick just after they have completed the last of their Christmas Eve repairs. A fact which does not stop Dick from picking up some useful tips on modern sound radio circuits

A MERRY CHRISTMAS, ALREADY!" "A Merry Christmas, yet!" With a chuckle, Smithy and Dick settled down comfortably on their respective stools. At that very moment, Santa Claus (a staunch anti-overtime union man if ever there was one, and in any case he's really St. Nicholas whose feast day is on 6th December) must have been in the process of harnessing up his eight reindeer, preparatory to delivering all manner of toys to good little boys and girls.

For this was Christmas Eve.

"It's been the same as every other Christmas Eve I can remember," remarked Smithy reflectively. "Just one mad panic to get all the sets out of the way!"

"I'll say," agreed Dick. "Why is it that all the sets in all the world go faulty during the week before Christmas Day?"

"It's just one of those things," replied Smithy. "Everybody wants their radios and tellys to be spot-on for the Day!"

Dick surveyed the Workshop. He and Smithy had spent the entire morning and part of the afternoon in a frantic rush, working frenziedly on the receivers which had piled up on the racks over the last seven days. At about two-thirty in the afternoon they had fought their way through to the last few sets whilst, at three o'clock, they had both simultaneously announced the successful completion of their final repair jobs.

The shelves holding sets for service were now empty. The last solder joint had been made, the ultimate meter reading had been taken, and the final knob had been pushed into position on its spindle. The Workshop floor gave evidence of the day's feverish activities in the form of an untidy layer of defunct capacitors, odd nuts and bolts, short lengths of insulation, and glistening star-splashes of solder. Smithy had decreed that the floor could stay as it was, whereupon Dick had crunched his way over the debris in the direction of the sink. It was whilst the pair were waiting for the battered Workshop kettle to boil that they had exchanged their Christmas greetings.

Overload Protection

"It's a funny thing," said Dick, "but, whilst on previous Christmas Eves I've spent nearly all my time working on TV's, this year I found I was doing practically nothing else but radios."

Smithy directed a suspicious glance at his assistant.

"That's funny, too," he remarked thoughtfully. "I seem to have spent all my time doing TV's!"

"Just the luck of the draw," commented Dick carelessly. "Anyway, I bumped into a most peculiar fault this morning. I cleared it up O.K., but in the process I bumped into a germanium diode which had no effect on circuit operation what-

soever!"

"That sounds interesting," commented Smithy. "What sort of set was it?"

"Just a small medium and long wave transistor radio," replied Dick, leaning over and picking up a service manual from his cluttered bench. "And it had a snag which appeared between the mixer/oscillator and the first i.f. transistor."

Dick showed Smithy the circuit diagram of the receiver and indicated the section in which the fault had occurred (Fig. 1).

"Ah yes," said Smithy, looking at the diagram. "I suppose the diode you're referring to is the one that's in the a.g.c. overload circuit. The one in series with the 680Ω resistor."

"That's right," confirmed Dick, "although I'm not too certain about this a.g.c. overload business. When the set came in it was very insensitive and I found that I could only get the local station at weak volume. Another point I noticed was that tuning seemed to be a wee bit broader than it ought to have been."

"So what," asked Smithy, "did you do?"

"The a.f. stages appear to be O.K.," replied Dick, "and the broadness of tuning made me suspect lack of alignment in the i.f. amplifier. So I popped the signal genny on and found that, whilst the second and third i.f. transformers were already peaked up nice and sharp, the first i.f. transformer

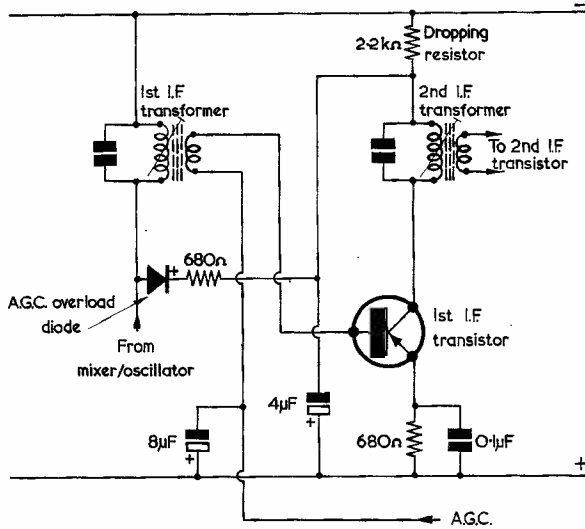

Fig. 1. The circuit around the a.g.c. overload diode in a typical medium and long wave transistor radio. The component values shown are representative of current practice

wouldn't peak up sharply at all. Despite the broad response, though, its core still appeared to be at the correct setting."

"I see," said Smithy. "What happened next?"

"It seemed obvious to me," said Dick, "that the first i.f. tuned winding was being pretty heavily damped in some way. The transformer had one tuned winding and a coupling winding, and it struck me that a shorted turn in the coupling winding could be causing the trouble."

"Why not the tuned winding?"

"If the shorted turn had been in the tuned winding," explained Dick, "its inductance would have altered and the core wouldn't have been in the position which seemed to offer best response."

"Very good," commented Smithy with approval. "What was your next move?"

"Well, you know what it's like getting those tiny little i.f. transformers out of printed circuit boards," grinned Dick. "I wasn't going to start an operation like that until I'd had a jolly good look elsewhere! And so I had a dig around with the ohmmeter, to find, eventually, that the diode in series with the 680Ω resistor seemed to have a short-circuit on it. To confirm this point I disconnected one leg of the diode from the circuit and checked it again. With the ohmmeter connected to it either way round that diode showed up as a dead short."

Dick paused for a moment.

"And then," he continued, "the real mystery started. I switched on the set with the diode out of circuit and it went like a bomb! After which I fitted a new diode, and this didn't make a blind bit of difference! The set worked exactly the same, regardless of whether the new diode was connected or not."

Smithy chuckled.

"That seems reasonable enough to me," he said, "and you'll soon understand why when I explain it to you. In medium and long wave transistor sets it's fairly usual to apply the a.g.c. voltage back to the

first i.f. transistor only. With a valve set, the a.g.c. line goes more negative as signal strength increases but, in a transistor set using p.n.p. transistors—which are the standard in this country—it has to go positive. The a.g.c. voltage is taken from the detector load (Fig. 2) and the detector is connected up in such a manner that the detected voltage goes positive of chassis. This voltage is then applied to the base of the first i.f. transistor via the i.f. transformer secondary winding. The result is that the gain of the first i.f. transistor reduces according to signal strength at the detector, with the consequence that you have an a.g.c. loop set up."

"I know all that," interrupted Dick, "but where does the second diode come in?"

"I'm coming to that," replied Smithy unhurriedly. "Now, the amount of control you get with the a.g.c. loop going back to the first i.f. transistor only is not excessively great, and it is possible for very strong signals to overload the receiver even when the a.g.c. voltage causes the controlled i.f. transistor to be practically cut off. If you look at the collector circuit of the first i.f. transistor you'll find that it includes a dropping resistor from the negative rail to the top of the i.f. transformer primary, together with an electrolytic bypass capacitor to the positive supply line. Under normal signal conditions, a voltage is dropped across that series resistor and this voltage is applied to the series combination of the 680Ω resistor and the diode you replaced. As you will note, the left-hand side of the diode connects to the negative supply rail via the primary of the first i.f. transformer. When the first i.f. transistor passes a normal collector

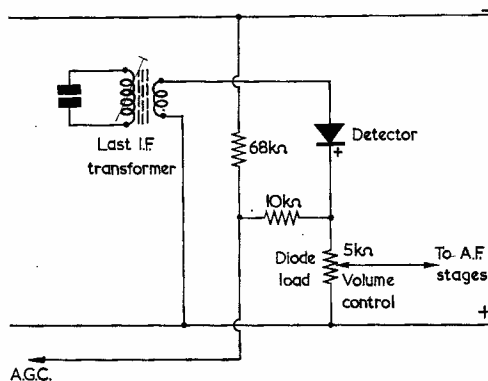

Fig. 2. The detected voltage in a transistor radio is positive-going in order that a suitable a.g.c. voltage may be obtained. In this typical circuit, the positive-going a.g.c. voltage is applied to the potential divider given by the 10kΩ and 68kΩ resistors in series

current the voltage dropped across its series supply resistor has a polarity which does not cause the diode to conduct. Under overload conditions, however, the voltage applied to the diode and 680Ω resistor drops practically to zero, whereupon the diode becomes partly conductive. The result is that the primary of the first i.f. transformer becomes damped and the signal passed to the first i.f. transistor is reduced in consequence. Thus, the diode increases the effectiveness of the a.g.c. circuit, and prevents the receiver from being overloaded on very strong signals."

"I see," said Dick, looking at the circuit. "Wouldn't the diode be more effective if the bottom of the first i.f. transformer primary was at a potential slightly positive of the negative supply rail? Instead of becoming partly conductive, it could then become almost fully conductive when the collector current of the first i.f. transistor dropped."

Smithy picked up a pencil and quickly drew a circuit in the margin of the service manual (Fig. 3).

"An arrangement of the sort you mean," he said, "is, in fact, used quite often. It includes a small resistor having a value of 100Ω or so in series with the feed to the first i.f. transformer primary. The addition of this resistor should definitely allow the diode to become more conductive under overload conditions, because its left-hand side now goes to a more positive point. In practice, though, set-makers use either version of the arrangement, and both versions seem to work equally well. Returning to the set you serviced, the reason why the new diode you put in didn't make any difference is because we don't have any exceptionally strong signals in this part of the world. If we were a lot closer to the local transmitter, the effect would have been very pronounced!"

Speaker Transformer Connections

At that instant the kettle burst forth into an ear-shattering whistle, and conversation ceased whilst Dick busied himself with the important business of preparing tea. Eventually, he carried a disgracefully stained and cracked cup over to the Serviceman, who commenced to drink its contents with great gusto and with many loud and appreciative smackings of the lips. Smithy enjoyed a cup of tea.

A sudden thought struck Dick, and he turned round and began rummaging in a drawer in his bench. After some moments he produced a grubby envelope, which he handed over to the Serviceman with a

flourish.

"Here you are, Smithy," he said. "I meant to give this to you this morning but I forgot all about it with the rush."

Smithy opened the envelope a little distrustfully, but his face broke into an ecstatic smile as he saw the contents.

"Well, that *is* nice," he said, delighted. "A Christmas card! And I do like the picture on the front, too. I always think that a candle with a bit of holly really *makes* a Christmas card. Now, let's see what the verse says."

"You don't read the verse inside, do you?"

"Of course I do," said Smithy indignantly. "What's the sense of having a Christmas card if you don't read the message inside?"

"Blimey," said Dick, impressed. "I didn't know that *anyone* ever looked at the verses in Christmas cards."

But Smithy had already started to read.

*"May comfort and joy
Dour sadness destroy
O'er this festive and light-hearted
time.*

*And may a good measure
Of light-hearted pleasure
Come to you when the Christmas
bells chime."*

"I now understand," commented Dick, wincing, "why people don't read the verses in Christmas cards!"

"Nonsense, boy," said Smithy. "That bit of poetry shows real understanding. Let me add your Christmas card to the other ones

I've got."

Smithy stood up, reached behind his signal generator and produced three other cards.

"Here we are," he pronounced grandly. "How about these?"

"What's the picture on the first one?" asked Dick, interested.

"It's the candle motif, again," replied Smithy, gazing fondly at the card, "only this time it's a candle and a robin."

"What's it say inside?"

"The Compliments of the Season," quoted Smithy opening the card, "from the sales staff of Alpha Valves Ltd. The only valve you can trust for a reliable repair."

"Very nice," commented Dick a little uncertainly. "What about the next card?"

"This one's got a candle, too," said Smithy, "together with a snowman. And it says 'Seasonal Greetings, and best wishes for increased business in 1964.'"

"Who's that from?"

"Gamma Components Ltd.," replied Smithy. "Don't you remember? We bought a whole pile of resistors from them in the summer."

"So we did," said Dick non-committally. "Let's have a look at the final card."

"This," pronounced Smithy, "is the best of the three."

He took up the card, looked at it affectionately, then passed it over to his assistant.

"Corluvaduk," exclaimed Dick. "It's another candle!"

"Ah yes," said Smithy. "But it's got tinsel stuff stuck all over it as

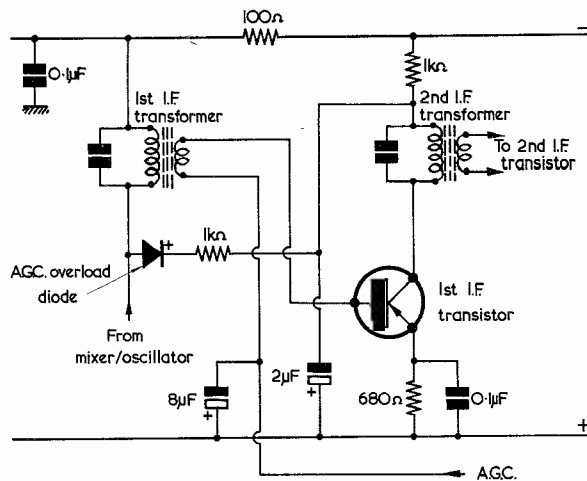

Fig. 3. An alternative circuit to that of Fig. 1, in which the "anode" of the diode is slightly positive of the negative supply line due to the addition of a small resistor in series with the mixer/oscillator negative supply. Again, representative component values are shown

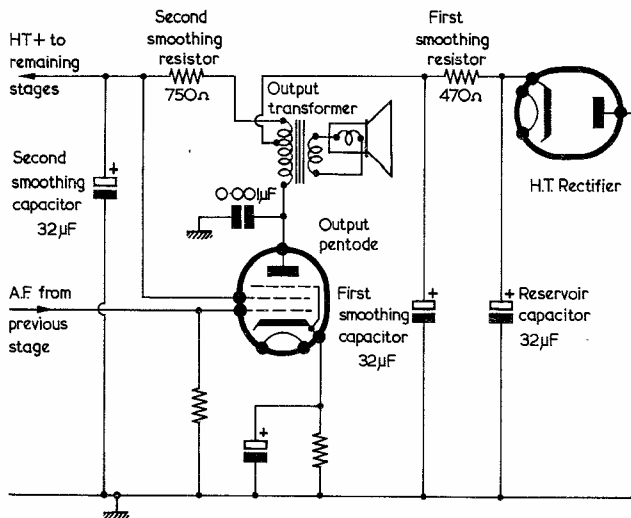

Fig. 4. A hum-cancellation circuit. Ripple currents from the first smoothing capacitor flow from the tap in the output transformer primary both towards the output pentode anode and towards the second smoothing resistor. The tap is so positioned that the ripple current fields in the transformer cancel out

well. I think the picture is most effective."

Dick opened the card.

"Well, this sounds a bit better," he remarked. "It says 'A Very Merry Christmas and a Truly Happy New Year from Mr. F. Thomas.' Who's Mr. F. Thomas?"

Smithy frowned.

"That's a bit of a puzzler," he remarked, "because, try as I might, I can't exactly place him. I'm pretty certain, though, that either he's the traveller for Beta Capacitors or he's the rep for Omicron Trade Supplies."

Smithy took the card from his assistant and set it up on the bench alongside the other three. The four candles, together with their various accessories, presented a garish, incongruous scene against the sombre background of test equipment, tools and spare components.

"Now isn't that," asked Smithy proudly, "a truly Christmassy scene? I've been really lucky with Christmas cards this year."

Dick decided it might be wiser to change the conversation.

"I had another queer little snag this morning," he pronounced hurriedly. "It was in an a.m./f.m. receiver which had a mild, but annoying, case of hum. I disconnected the speaker to get the chassis out, and when I reconnected it the hum had completely cleared!"

Reluctantly, Smithy tore his gaze away from his beloved Christmas cards.

"That sounds a bit peculiar," he remarked. "Have you got a circuit for the set?"

Dick delved into the litter on his bench and produced a second service manual.

"Here you are," he remarked. "The speaker is connected up in the circuit shown here (Fig. 4). There are three wires from the chassis which terminate in pins, and these fit into sockets on the output transformer, which is mounted on the speaker frame."

Smithy looked at the circuit.

"I should guess," he commented, without any hesitation, "that the connections to the speaker transformer primary were wrong way round when the set came in. You must have re-made the connections correctly."

"That's quite possible," said Dick.

"You see I didn't bother to see which pin went to which socket when I removed them to get the chassis out, because I had the manual with me. I then put them back as per service manual, with the result that I must have automatically cleared the snag!"

"That would be about it," confirmed Smithy. "Someone, probably the set-owner, must have been messing about with the set before it came into the shop."

"Even so," said Dick. "The thing is still puzzling. How on earth can you get hum by messing around with speaker connections?"

"Easily enough," commented

Smithy, "when you have an output circuit such as that employed in this particular receiver. If you look at it you'll see that the voltage across the first h.t. smoothing capacitor is applied to the tap in the transformer primary, with the result that some of the h.t. current flows towards the output valve anode, whilst the remainder flows towards the second smoothing resistor and the second smoothing electrolytic. At which point, incidentally, the output valve picks up its screen-grid supply. There'll be a fair amount of ripple voltage across the first smoothing capacitor, and a corresponding ripple current will flow through the lower part of the transformer primary towards the output anode. The remainder will flow through the upper winding towards the second smoothing resistor. The two ripple currents flow in opposite directions, and the tap in the output transformer is so positioned that their fields cancel out. The result is that you get a nice high voltage on the output valve anode and there's only a low hum level from the speaker. In the set you encountered the h.t. for the output anode is taken from the first smoothing electrolytic. However, you'll often find this tapped transformer idea used in circuits where h.t. for the output valve anode is obtained direct from the reservoir capacitor (Fig. 5). In this case you have the further advantage that the anode which draws the most current in the receiver is not fed via a smoothing resistor at all, with the consequence that excessive dissipation and volts drop in the latter are avoided."

"That's a knobby scheme," said Dick enthusiastically. "I should imagine that, when the set I handled came in, the two connections at the top end of the output transformer primary had been changed over, with the result that the two ripple currents were aiding, instead of opposing each other."

"That seems very likely," agreed Smithy. "Incidentally, I hope you didn't happen to switch the set on without any connections made to the transformer primary."

"I didn't actually," said Dick, puzzled, "but why shouldn't I have done?"

"Because," pronounced Smithy, "it is always a dicey thing to run an a.f. output valve with an open anode circuit. If the anode receives no h.t. there is heavy dissipation at the screen-grid, and this electrode can go red-hot as a result. The outcome is that the valve may pack in much earlier in life than it should do."

Base Bias Control

"Fair enough," said Dick. "I'll keep an eye open for that in future. Incidentally, I had a transistor set this morning . . ."

"Any more tea in the pot?" interrupted Smithy.

Dutifully, Dick rose and replenished the disreputable utensil which Smithy handed over to him.

"As I was saying," he remarked, "I had a transistor set in . . ."

"Not too much milk, now," interrupted Smithy.

Dick turned an exasperated scowl on the Serviceman.

"I never *do* put in too much milk," he retorted. "Now, about this transistor . . ."

"Yes, you do," contradicted Smithy rudely. "You put in too much milk about a week ago. I had to empty half the cup away and top it up again."

Dick turned an anguished eye upwards.

"And to think," he said bitterly, addressing the ceiling, "that this is Christmas Eve!"

"You still have to drink tea on Christmas Eve," Smithy pointed out, "just as much as any other day."

Dick shrugged his shoulders and relinquished the unequal contest.

"Well, anyway," he said, sitting down again. "There's this transistor radio I had this morning."

"What about it?"

"It had an extra transistor," replied Dick, "stuck in series with the positive supply line!"

"There's nothing queer about that," said Smithy. "It was probably fitted to prevent changes in ambient temperature and falling battery voltage from upsetting the output stage. Several transistor radios employ circuit devices like that."

Dick turned and extracted yet another service manual from the debris on his bench.

"You *have* been taking advantage of the service manuals this morning," commented Smithy.

"I always do," replied Dick. "I've found that, in the long run, it saves a lot of time."

"Two or three years ago," said Smithy reminiscently, "it was all I could do to get you to even *look* at a manual. In those days you'd rather waste a couple of hours tracing out a circuit than just spend thirty seconds getting the service sheet out in the first place!"

But Dick refused to deviate from the subject which was uppermost in his mind.

"Here's that transistor I mentioned," he said, pointing to a section of the circuit in the manual. "And what's more, it's shown as a diode!

(Fig. 6 (a)). As you can see, it's in series with the positive supply line and it's got a pre-set pot connected across it."

"Ah yes," said Smithy. "Also, the slider of the pot goes to the centre tap of the driver transformer secondary, whereupon it varies the bias on the output transistor bases. We'll refer to the series transistor as a diode for the time being, whereupon you can see that the current drawn by all the transistors in the set except the output transistors flows through it in the forward direction. A further amount of current is also drawn through the diode by way of the 3.9k Ω resistor up to the negative supply line. Despite the fact that the series diode is conducting, there will still be a significant volts drop across it. A fraction of this potential is tapped off by the pre-set potentiometer and applied to the bases of the output transistors in the form of bias. O.K.?"

"Yes, sure," replied Dick. "It's clear enough up to now."

"Right," said Smithy briskly.

"We'll now carry on to the case of differing ambient temperature conditions. If, to take an example, the ambient temperature goes up, the output transistors will tend to draw a larger current, whereupon quiescent current increases and the transistors cease to operate under optimum Class B conditions. With the present circuit, however, the rise in ambient temperature causes the diode in the positive supply line to pass an increased current as well, which is the same as saying that its forward resistance drops. The result is that the bias voltage applied to

the bases of the output transistors drops also, bringing them back to their correct Class B operating point."

"I think I see what you mean," said Dick frowning. "The voltage on the left-hand side of the diode is negative of the positive terminal of the battery, to which the output transistor emitters are returned. Therefore, the diode causes the output transistor bases to have a negative bias. When ambient temperature rises, this negative bias becomes less, and counteracts the tendency towards increased current in the output transistors."

"You've got it," said Smithy. "And, of course, the opposite thing happens when the ambient temperature decreases. In this instance the output transistors tend to draw less current and, at very low temperatures, they may even become almost cut off under quiescent conditions. Whereupon distortion at low volume levels could become somewhat unpleasant. With the circuit we're discussing, though, the series diode exhibits increased resistance at low temperatures, causing the bias applied to the bases of the transistors to go more negative and to counteract their tendency to pass reduced current."

"Well, that's a neat idea," exclaimed Dick. "What setting should the pre-set pot have?"

"It would normally be set up to give a pre-determined quiescent current in the output transistors," replied Smithy. "After which it wouldn't have to be adjusted. In practice the series diode normally consists of the emitter-base junction

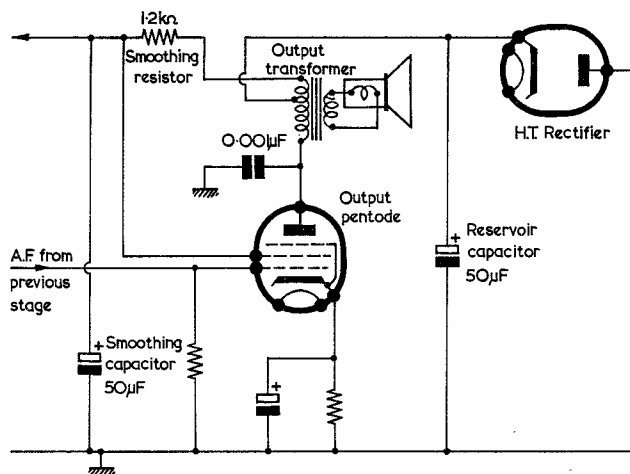

Fig. 5. Another hum-cancellation circuit. This functions in the same manner as that of Fig. 4, but there is only one set of smoothing components

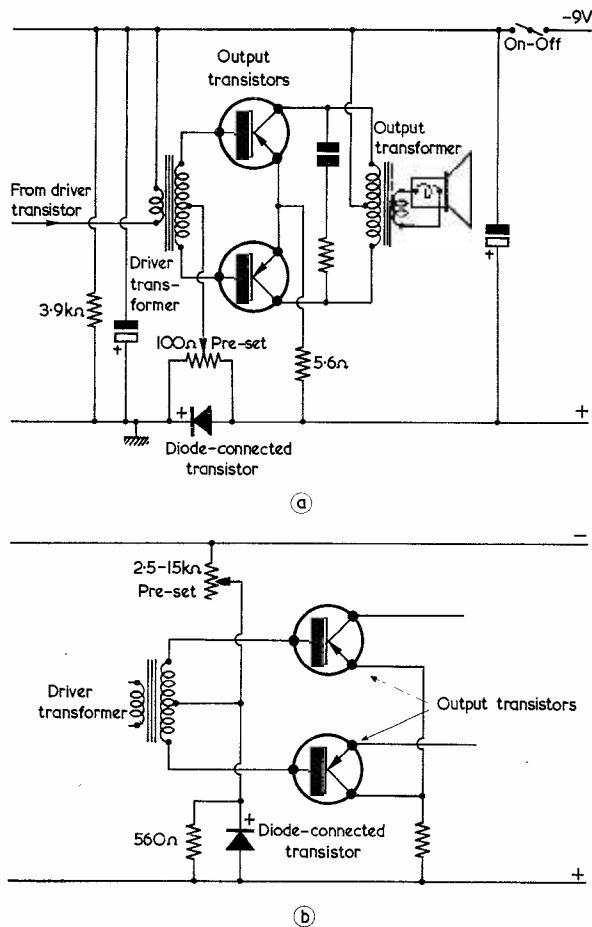

Fig. 6 (a). A compensating circuit which automatically adjusts output transistor bias for different ambient temperatures
 (b). Another compensating circuit which functions in basically the same manner

of a transistor of the same type as is employed in the output stages, with the result that it has a similar forward resistance/temperature characteristic. This is of help in the present function. Another factor is that the forward current/resistance characteristic will be non-linear in something of the same manner as occurs in the emitter-base junctions of the output transistors. In consequence, it will assist in keeping these transistors at the correct operating point when battery voltage falls."

Smithy paused for a moment and sipped his tea.

"There is," he continued, "another version of the circuit which you may also encounter. This operates on the same principle and it also employs a transistor connected as a diode.

However, the diode is, this time, connected between the positive supply line and the centre-tap of the driver transformer secondary, an adjustable current being made to flow through it by a pre-set potentiometer connected to the negative supply rail (Fig. 6 (b)). This circuit functions in much the same manner as the previous one and it offers the same advantages."

Tuning Capacitances

"Well, that's cleared up another of my mysteries," said Dick eagerly. "There's only one more point I wanted to ask you about."

"Dash it all," said Smithy, "this is Christmas Eve, you know!"

"Just one query."

"All right then," said Smithy,

relenting. "Seeing that it's Christmas. After all, you did give me a card!"

"Fair enough," said Dick. "Besides, this one is a quickie. It has to do with tuning capacitors for medium and long waves."

"Fire away."

"Well," said Dick. "In the old days we used to reckon that you couldn't cover the medium or long wave bands with anything smaller than a 500pF tuning capacitor. But, nowadays, set-makers use tuning capacitors with fantastically small values of around 200pF, or even lower. If you can tune over either of these bands with a 200pF capacitor now, why couldn't we do so in the old days?"

"That," remarked Smithy, "is a very good question, and it's one that's given me a little thought, too. The main reason is that modern ferrite frames and pot core coils have much lower self-capacitances than the old frame aeriels and open coils we used to employ. Even so, there was a strong tendency in the old days to stick in the 500pF tuning capacitor groove, and it may well be that manufacturers didn't realise that they were using much higher tuning capacitances than were really needed. In the old days, too, most sets had a short wave band as well, and you needed a fairly large tuning capacitor to cover the range of 5 to 20 Mc/s or so which was considered commercially acceptable. Three-band switching introduced additional stray capacitances across the tuned circuits, and this also made it desirable to use high value tuning capacitances."

"You keep talking," commented Dick, "about stray capacitances and self-capacitances; but I don't quite see what their importance is. After all, you don't get maximum tuning capacitance until the tuning capacitor is fully closed. And the stray and self-capacitances you get then are much lower than that offered by the tuning capacitor."

"Perhaps so," said Smithy. "But you've missed the entire point! The stray and self-capacitances limit tuning range when the tuning capacitor is at *minimum* value."

"Hey?"

"Let's work out an example," said Smithy in reply, "to illustrate that point. Now, what's the formula for resonant frequency?"

"That's easy," said Dick promptly. "One over two pi root LC"

Gives you the resonant frequency!"

"You've certainly got that one off pat," chuckled Smithy, pulling a pad towards him. "So let's jot it down:

$$f = \frac{1}{2\pi\sqrt{LC}}$$

It'll make things easier for the moment if we square both sides, giving us:

$$f^2 = \frac{1}{4\pi^2 LC}$$

Smithy scribbled the second equation down on the pad.

"Let's next assume," he continued, "that we have a coil which resonates at the low frequency end of the medium wave band when a capacitor having a value of C_1 is connected across it. We can say for the time being that we are referring to frequency in cycles per second, inductance in henrys and capacitance in farads but, as you will shortly see, the units chosen are not of importance in the present exercise, provided we stick to the same ones throughout. Now, the lowest medium wave frequency is about 500 kc/s, corresponding to 600 metres, which gives us:

$$(500,000)^2 = \frac{1}{4\pi^2 LC_1}$$

We now carry on to find the tuning capacitance needed for the highest frequency in the medium wave band, and we shall call this C_2 . The highest frequency is around 1.5 Mc/s, corresponding to 200 metres, which then gives us:

$$(1,500,000)^2 = \frac{1}{4\pi^2 LC_2}$$

"The next step is to divide the C_1 equation by the C_2 equation, whereupon we have:

$$\frac{(500,000)^2}{(1,500,000)^2} = \frac{4\pi^2 LC_2}{4\pi^2 LC_1}$$

$$\left(\frac{500,000}{1,500,000}\right)^2 = \frac{4\pi^2 LC_2}{4\pi^2 LC_1}$$

$$\left(\frac{1}{3}\right)^2 = \frac{C_2}{C_1}$$

$$\frac{1}{9} = \frac{C_2}{C_1}$$

$$C_2 = \frac{1}{9}C_1$$

"I'm with you so far," broke in Dick. "Where do we go from here?" "We have learned," said Smithy,

"that to cover the medium wave band we need a minimum tuning capacitance which is $\frac{1}{9}$ the maximum tuning capacitance. Now the minimum tuning capacitance consists of trimming capacitances and the stray and self-capacitances which we've just mentioned, whilst the maximum tuning capacitance consists of the trimming, stray and self-capacitances plus the maximum value of the tuning capacitor. If we call the latter C_T and the trimming, stray and self-capacitances C_S , our last equation changes to:

$$C_S = \frac{1}{9}(C_T + C_S)$$

$$9C_S = C_T + C_S$$

$$8C_S = C_T$$

$$C_S = \frac{1}{8}C_T$$

"I see," said Dick thoughtfully. "What all this comes out to, therefore, is that we can cover the medium wave band provided that all the trimming, stray and self-capacitances come to $\frac{1}{8}$ of the maximum value given by the tuning capacitor."

"That's right," confirmed Smithy. "And you can cover an even greater range if the trimming, stray and self-capacitances are less than the $\frac{1}{8}$ value. The $\frac{1}{8}$ figure means that, if you use a 200pF tuning capacitor, you can cover the medium waveband if all the trimming, stray and self-capacitances are less than 25pF. To be really accurate, you must add the minimum capacitance of the tuning capacitor itself to the trimming, stray and self capacitances. Thus, if you have a capacitor with a range of 8 to 208pF, you add the 8pF minimum capacitance to the trimming, stray and self-capacitances, and assume a maximum tuning capacitor value of 200pF."

"What", asked Dick, "about the long waveband?"

"Things are easier there," said Smithy. "You only need to cover 1,000 to 2,000 metres, or 300 to 150 kc/s. This is a frequency ratio of 2:1 instead of the 3:1 figure you get on medium waves. With the result that C_S can be higher than the value needed for full medium wave coverage."

"What about the oscillator tuned circuits?"

"These," said Smithy, "are also easier. The medium wave case we have just discussed corresponds to the aerial tuned circuit of a superhet. Assuming an i.f. of 465 kc/s, the oscillator frequency coverage would then be 1,965 to 965 kc/s, this representing a ratio which is, once again, lower than the 3:1 figure given by 1,500 and 500 kc/s."

"I see," said Dick. "I've just remembered that, in any case, the oscillator tuning capacitance is always lower in value than the aerial circuit tuning capacitance."

Closing Up

"Exactly," said Smithy.

The Serviceman rose and walked across the Workshop.

"Where've you hidden it this year?" called out Dick.

"At the back of the valve cupboard," chuckled Smithy. "So it is, perhaps, a good thing you concentrated on transistor sets this morning, after all!"

He rummaged in the recesses of the cupboard, and eventually produced a bottle and two glasses.

"I see," he remarked, as he returned to his bench, "that we're running very low on PL81's."

"Blow the PL81's," snorted Dick. "This is Christmas!"

"And so it is," agreed Smithy, passing a charged glass to his assistant. "Here's mud in your eye!"

"The same to you," replied Dick warmly. "And, as I said just now, a Merry Christmas, already!"

"Indeed," chuckled Smithy. "A Merry Christmas, yet!"

Dick stood up.

"We must also," he pronounced, "wish a Merry Christmas to the readers who've put up with our adventures over the last twelve months."

"We must indeed," confirmed Smithy, rising and holding up his glass. "A very Merry Christmas to you all!"

"And let us end," added Dick, "as we always do, by saying 'God Bless Us, Every One!'"

EMI Awarded Malaysian TV Contract

EMI Electronics Ltd. has been appointed principal contractor for the supply of television studio and outside broadcast equipment to the Ministry of Information and Broadcasting, Malaysia.

The Company has been awarded a contract worth approximately £100,000 for equipment for the First Phase of the Malaysian Television Service. This will provide a television service for the Kuala Lumpur area and is scheduled to commence in this month.

Included in the contract are two image orthicon camera channels, vision and sound mixers and ancillary equipment for a medium-sized studio, a complete master control installation and an outside broadcast vehicle equipped with three-image orthicon camera channels.

The contract—which was secured in the face of competition from manufacturers in Japan, the United States of America, and Europe—was negotiated by A. D. G. Wheatley, EMI's resident engineer in the Far East, acting in conjunction with Jardine Waugh (Malaya) Ltd., EMI's local agents.

Cover Feature

COMPACT CONSTRUCTOR'S TUNER

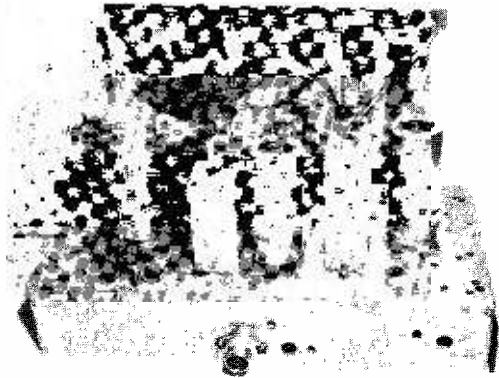

By A. S. Carpenter, A.M.I.P.R.E.

Details of a sensitive self-powered a.m. superhet unit which can be used with a tape recorder or audio amplifier

ALTHOUGH INITIALLY CONSTRUCTED FOR USE WITH tape recording equipment this sensitive and self-contained a.m. superhet tuner is an attractive proposition for other uses. It can, for example, provide the "radio" function in a radiogram under construction since the output it affords is comparable with that provided by a crystal pick-up. If the audio amplifier used with the tuner is a quality push-pull type very pleasing results are obtained. Details of a suitable amplifier (which uses a chassis of similar dimensions and which has been tested with the tuner) appeared in an earlier issue of this journal.¹ The tuner may also be coupled to simpler two-stage audio amplifiers built around a triode-pentode valve such as the Mullard ECL86, etc.

The real hi-fi enthusiast usually prefers to use a v.h.f. tuning unit with his equipment but, to a beginner at any rate, this may mean purchasing a

ready-made and fairly expensive item. However, very good results at comparatively low cost have been obtained from utilising the set-up depicted in Fig. 1, where the audio system monitors the signals to the recorder on "record". When a recording session is completed the tuner is switched off, the tape wound back from spool B to spool A and the tape recorder function set to "playback". The recorded material then becomes available via the audio system immediately the recorder "start" button is depressed. Should one later require to listen to radio transmissions direct, this can be done by using the tuner positioned as shown and switched to "record" (but with no tape running) or, alternatively, by plugging the tuner direct to the audio amplifier whereupon the recorder may be switched off.²

V.H.F. and transistorised superhet tuners may

¹ Wallace Studley. "Useful Push-Pull Amplifier", *The Radio Constructor*, February 1963.

² The precise mode of working will depend upon the kind of recorder in use.

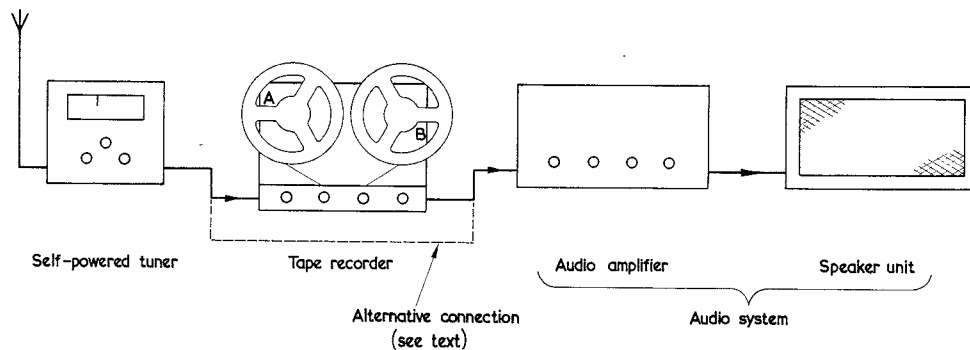

Fig. 1. Block diagram showing a suggested set-up for the tuner and associated equipment

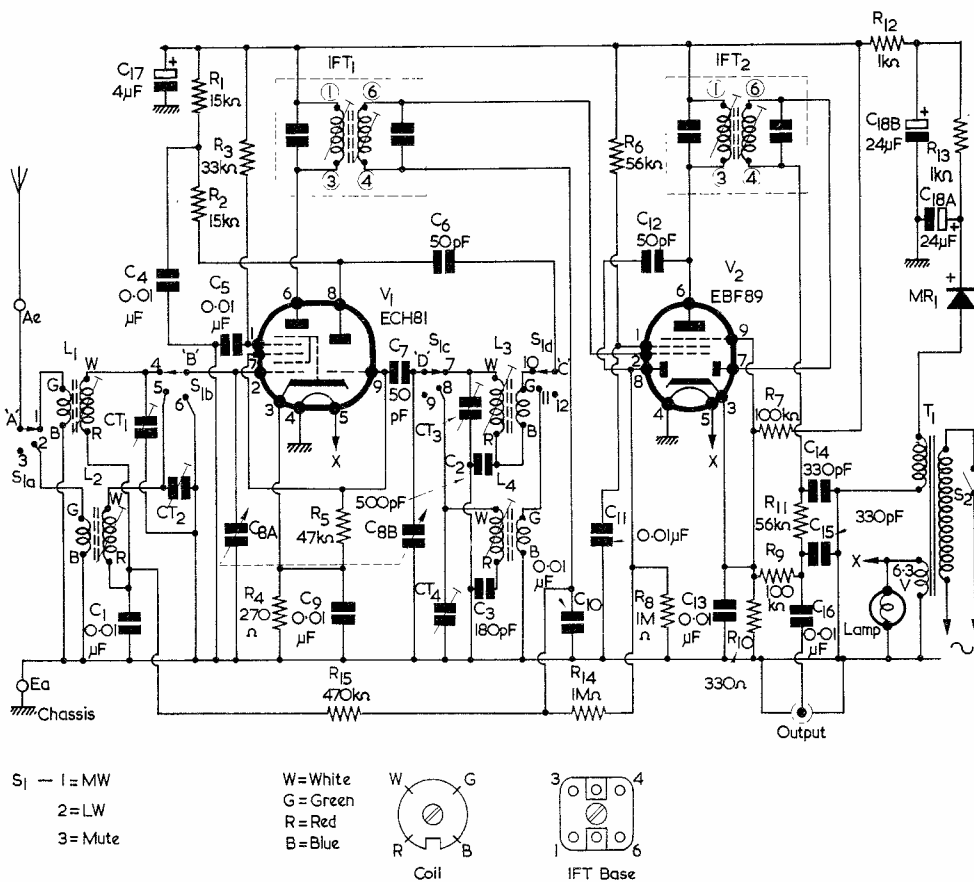

Fig. 2. The circuit of the tuner

Components List

Resistors (all resistors 10% 1/2 watt unless otherwise stated)

- R₁ 15kΩ 1 watt
- R₂ 15kΩ 1 watt
- R₃ 33kΩ
- R₄ 270Ω
- R₅ 47kΩ
- R₆ 56kΩ
- R₇ 100kΩ
- R₈ 1MΩ
- R₉ 100kΩ
- R₁₀ 330Ω
- R₁₁ 56kΩ
- R₁₂ 1kΩ 1 watt
- R₁₃ 1kΩ 1 watt
- R₁₄ 1MΩ
- R₁₅ 470kΩ

- C₃ 180pF silver mica, 1%
- C₄ 0.01μF ceramic or paper
- C₅ 0.01μF ceramic or paper
- C₆ 50pF silver mica
- C₇ 50pF silver mica
- C₈ 500+500pF (nominal) twin-gang (see text)
- C₉ 0.01μF ceramic or paper
- C₁₀ 0.01μF ceramic or paper
- C₁₁ 0.01μF ceramic or paper
- C₁₂ 50pF silver mica
- C₁₃ 0.01μF ceramic or paper
- C₁₄ 330pF silver mica
- C₁₅ 330pF silver mica
- C₁₆ 0.01μF ceramic or paper
- C₁₇ 4μF elec. 275V wkg
- C₁₈ 24+24μF elec. 275V wkg
- CT₁₋₄ 30pF trimmers, Philips concentric

Capacitors

- C₁ 0.01μF ceramic or paper
- C₂ 500pF silver mica, 1%

Valves

- V₁ ECH81
- V₂ EBF89

Inductors

L₁ HA3
L₂ HA1
L₃ HO3
L₄ HO1

Weyrad "H"
range

IFT_{1, 2} Denco type IFT11

T₁ Mains transformer. Secondaries: 220V at 25 mA; 6.3V at 1A (2 $\frac{3}{8}$ in mounting centres)

Rectifier

MR₁ Electrix contact-cooled, 250V at 50mA

Dial and Drive

SL16/5191 dial and drive complete. Jackson Bros.

Chassis

8 $\frac{1}{4}$ x 4 $\frac{1}{4}$ x 1 $\frac{3}{8}$ in (Fig. 5). Available from Oliver & Randall Ltd., 40 Perry Hill, London, S.E.6.

Sockets

2 B9A valveholders
Aerial-earth sockets
Coaxial output socket
2 clip-on panel lampholders (see text)

Switches

S₁ Rotary 4-pole 3-way. "Miniature" wave-change
S₂ Rotary on-off, toggle

Miscellaneous

3 $\frac{3}{8}$ in grommets
1 3-way tagstrip
1 stand-off insulator
Panel material (Fig. 6)
2 panel lamps, 6.3V 0.15A (see text)

also be used with the set-up depicted in Fig. 1, but these types tend to be less simple than the version presented here, whilst both are initially more expensive. T.R.F. valve or transistor "front ends" can also be tried, but might prove disappointing due to low sensitivity and poor selectivity. In general, the superhet form is to be preferred and, despite certain weaknesses inherent in a.m. reception, it must be appreciated that no other arrangement can provide the same high degree of sensitivity and selectivity within the compass of only two valves!

The Tuner Circuit

The circuit is shown in Fig. 2, in which V₁ operates as the frequency changer whilst V₂ provides amplification at the intermediate frequency together with signal demodulation and a.g.c. The demodu-

lated signal appears at C₁₆, from which component the audio content is passed to the output socket. The impedance here is approximately 100k Ω , which ensures a satisfactory a.c./d.c. load ratio when the volume control or other input resistance of the following equipment is not less than 500k Ω . The demodulating diode d.c. load is provided by R₉, capacitors C₁₄ and C₁₅, together with resistor R₁₁ forming filtering elements to dispose of unwanted r.f. Due to the cathode current of V₂, and to R₇ and R₁₀, a delay potential of about 2 volts positive with respect to chassis appears at pins 3 and 9 of this valve. The a.g.c. diode is, therefore, inoperative until signal peaks exceed the delay voltage, whereupon it conducts and applies a negative a.g.c. potential to both valve grids. The operation of this part of the circuit can be checked when the unit is com-

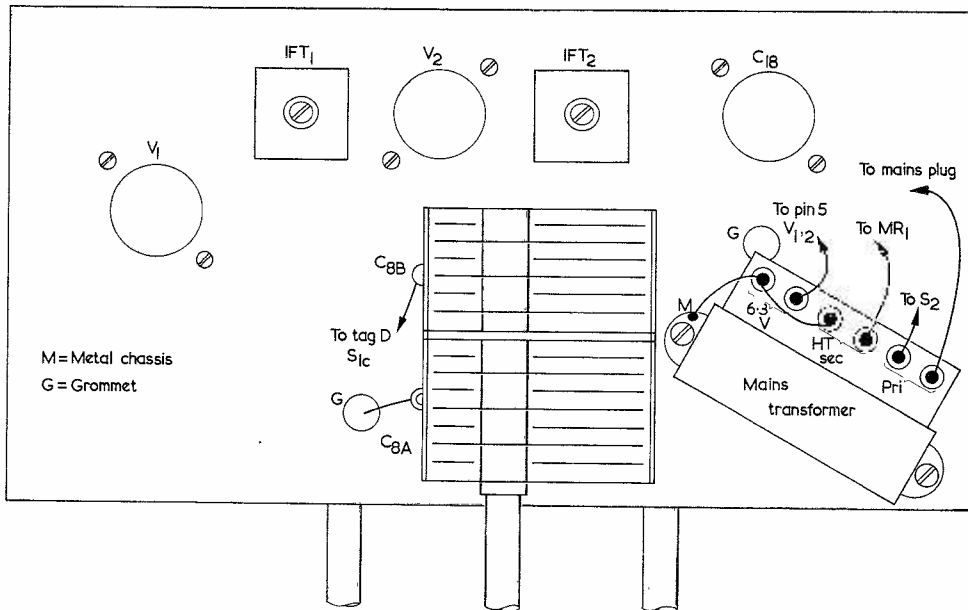

Fig. 3. The above-chassis layout

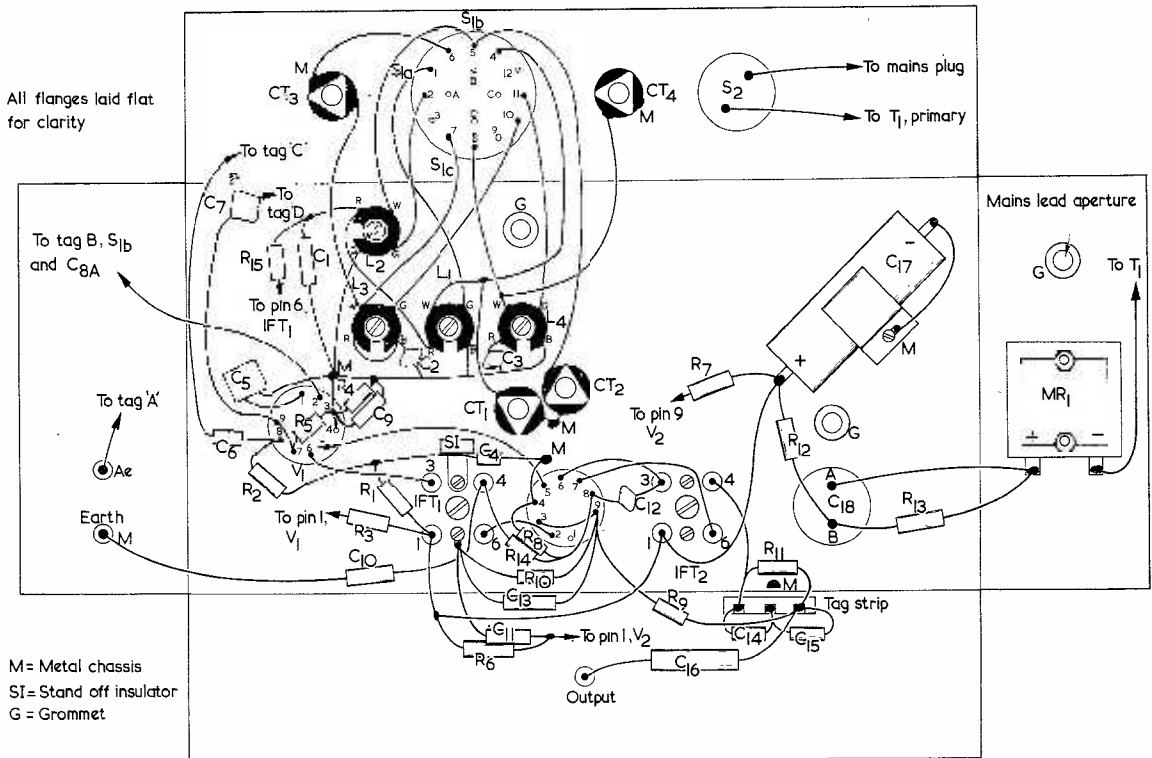

Fig. 4. The layout below-chassis. The contacts associated with each switch pole should be identified before wiring, as they may vary in position from those shown here

pleted by tuning to a strong signal and then momentarily short-circuiting C_1 to chassis. This will cause volume to increase. If, on the other hand, a weak signal is tuned in, no difference in volume level will be noted when the short-circuit is applied, as there is insufficient signal present to override the delay voltage. In this way weak signals are allowed maximum gain facilities whilst strong transmissions heavily bias the valves back into a quieter operating region. The signal necessary to operate the a.g.c. circuit is received via the aerial and, although this may seem obvious, it is not always sufficiently well appreciated by some users of a.m. equipment who expect good results with no aerial connected. The result in such an instance is excessive noise.

The Coils and I.F. Transformers

All coils, L_1 to L_4 , are selected from the Weyrad "H" range, each coil being easily retained by means of a single 6BA bolt. The small physical size of these coils (only 1in high) is a further asset and all tags are brought out to a rugged Paxolin ring situated around a brass slotted stem carrying the variable dust core. Colour-coded designations appear in Fig. 2.

Coils L_1 , L_2 are medium and long waveband types respectively whilst L_3 , L_4 are the necessary oscillator counterparts. Only one pair are in use at a given time and each coil is fitted with a trimmer for individual adjustment. The circuit arrangement around each aerial coil is identical, but a small variation will be noted in the oscillator section where the padding capacitors are C_2 and C_3 . Whilst the blue tag of L_3 connects direct to the red tag, blue on L_4 connects to chassis. This method of connection agrees with the maker's recommendations. In some cases, fitment of an intermediate frequency wave-trap coil might be desired and this may easily be done by mounting it, *sub-chassis*, in series with the aerial input socket and tag A of S_1 . Such a coil should be tuned precisely to the intermediate frequency, i.e. 470 kc/s.

The miniature i.f. transformers employed provide both high gain and selectivity, but care must be taken at the alignment stage to ensure that the dust cores do not become screwed in too far. Excessive coupling between the windings will give rise to instability. The circled numerals associated with the transformers in Fig. 2 refer to the base connections, for which see the inset diagram.

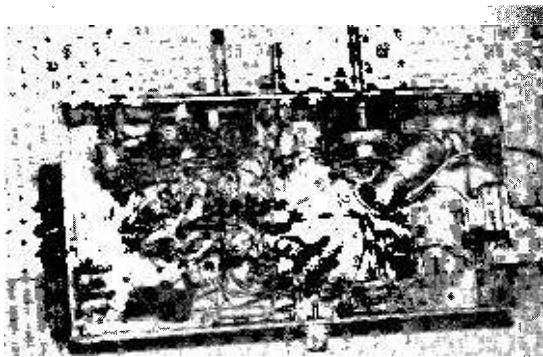

Below-chassis view of the Tuner Unit

Power for the Tuner

The modest power requirements allow a very small mains transformer to be used. The mains supply is completely isolated by T_1 and, after rectification, a potential of some 220V positive with respect to chassis appears at $C_{18(a)}$. The filtering and smoothing components comprise C_{17} , C_{18} , R_{12} and R_{13} , and are adequate due to the low h.t. current demands. Various half-wave type mains transformers exist at the present time but physical size is of importance and increases in proportion to h.t. secondary output voltage.

Tuning Scale and Drive Mechanism

Although the Jackson Bros. slide rule drive (graduated 0-100) which is specified is normally associated with v.h.f. apparatus it has proved very satisfactory in the prototype. Other drives may, however, be employed if desired. Other available types tend to be larger, though, and as height was a problem in the original tuner the type chosen was considered most suitable. The dial plate is silver and the inscriptions red and black. A bronze escutcheon, with glass fitted, is supplied.

Constructional Notes

Complete layout and wiring diagrams for the tuner are given in Figs. 3 and 4, these showing the above- and below-chassis layouts respectively. The essential chassis drilling details are shown in Fig. 5.

Panel lamps (not shown) are retained to the dial plate with clip-on holders, the lamp leads being twisted together and connected to the 6.3V winding on T_1 . If one lamp is used (and assuming a 1A heater winding rating for T_1) a 0.3A bulb may be used. Where two are employed each should be rated at 0.15A max.

Initial work consists of preparing the chassis and tentatively locating C_8 , together with the integral tuning scale and drive. The spindle of C_8 should be shortened to $\frac{3}{8}$ in and inserted in the drive drum aperture. The assembly is then placed on the chassis so that its tuning shaft is spaced equidistantly from the hole centres provided for S_1 and S_2 .

When correctly located, the spindle lock nut at the rear of C_8 should lie between the cans of IFT₂ and V_2 when these are placed in position. The capacitor back plate should almost touch V_2 screening can.³

The metal dial should now lie off the chassis front flange by $\frac{1}{4}$ in and two spacers of this length will be required later, when a 4BA bolt is passed through each of the holes provided at the foot of the scale and thence through the chassis.

The dial assembly $\frac{1}{4}$ in control knob spindle is finally shortened so that it projects by approximately $\frac{1}{2}$ in.⁴ The spindles of S_1 and S_2 should be sawn off before mounting so that they are the same length as that used for tuning.

When C_8 is correctly located it may be mounted. The scale may be removed and placed carefully on one side so that it will not get scratched.

The output coaxial socket is mounted on the rear flange of the chassis. If 3-core cable is used in conjunction with the mains supply pair, the green lead of this may be used for earthing.

When mounting S_1 locate the tags 1, 2 and 3 which correspond to tag A, and fit the switch as shown in Fig. 4. When correctly orientated commence wiring with section $S_{1(c)}$ (tags D, 7, 8, 9).

The below-chassis wiring is short enough to permit direct wiring, and only a single small tagstrip plus a stand-off insulator are needed as anchors. The wiring associated with S_1 and the coils is considerably shorter than indicated in Fig. 4 as, here, the flanges are drawn laid flat to reveal the connections clearly. No difficulty need be experienced provided a soldering iron with a pencil bit is used, together with modern, physically small, capacitors. During actual wiring it may sometimes be found that a more direct connection can be made to that shown in the diagram. For instance, R_7 could be soldered between pin 9 of V_2 and pin 1 of IFT₂ instead of as shown, whereupon the lead-out wires become no longer than $\frac{1}{4}$ in. Slight variations of this nature are unimportant provided that they result in shorter wiring. Each of the four concentric trimmers is secured by firmly soldering the central lug protruding from the base of each to a solder tag at the points shown. Due to the particular locations of these trimmers no difficulty will be found in making adjustments at the alignment stage.

A panel similar to that shown in the illustrations may be fitted, details for this being given in Fig. 6. This point is discussed at the end of the article.

Testing

When wiring is complete the dial may be fitted as described earlier and the valves inserted. Before the unit is connected to the mains an ohmmeter check should be made to see that no direct short-circuit exists between the h.t. positive rail and

³ The tuning capacitor employed by the writer had a spindle centre height, above chassis when mounted, of $1\frac{1}{8}$ in, and an overall depth (front to back plate) of $2\frac{1}{4}$ in. It would be advisable to employ a capacitor of similar spindle height and the same depth or less. A capacitor which meets these requirements is the Jackson Bros. Type F, Cat. No. 5040.—EDITOR.

⁴ The dimension required here may vary for panels or knobs different from those employed in the prototype.—EDITOR.

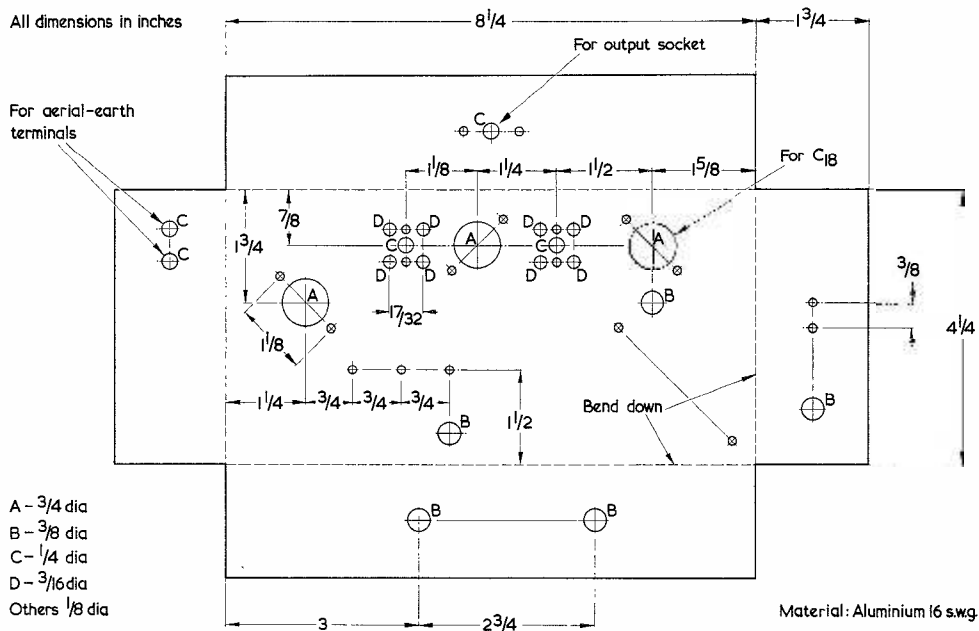

Fig. 5. Essential chassis details

chassis. If all is in order a screened lead may be prepared (coaxial cable is suitable for short lengths) one end being fitted with a plug to suit the tuner output socket and the other to fit the particular amplifier, etc., with which the tuner is to be used. The two units may then be interconnected. *It must be noted that on no account must the tuner be connected to any a.c./d.c. apparatus or to so-called a.c. equipment that derives its h.t. direct from the mains and has a live chassis.*

Simple Alignment

Briefly, alignment may be carried out as follows:

With S₁ set to medium waves and the vanes of C₈ fully enmeshed, a 470 kc/s amplitude-modulated r.f. signal applied to the aerial-earth sockets should be heard via the audio system in use. Only a weak signal should be used and this should be peaked by adjusting the cores of IFT₂ and IFT₁ in that order, attenuating the input signal as required. The generator is then switched to 600 kc/s and the core of L₃ is slowly adjusted until the signal is again heard, whereupon the core of L₁ is also adjusted for maximum output. If C₈ is now rotated anti-clockwise the signal should reappear at 1,200 kc/s, the vanes then being almost fully disengaged. Trimmers CT₁ and CT₃ are then adjusted for best results. This procedure is repeated and final adjustments are made using actual transmissions. It might be found beneficial to rock the tuning capacitor slightly when making adjustments at the low frequency end of the band. Should any instability manifest itself, slightly detune the i.f. secondaries, a process which should

also improve quality. The long wave aerial and oscillator coils are adjusted in exactly the same way but using the appropriate signal frequencies. Ideally, the four trimmers should be screwed fairly well down on completion.

Attempting Alignment without a Signal Generator

The tuner can be roughly aligned without the aid

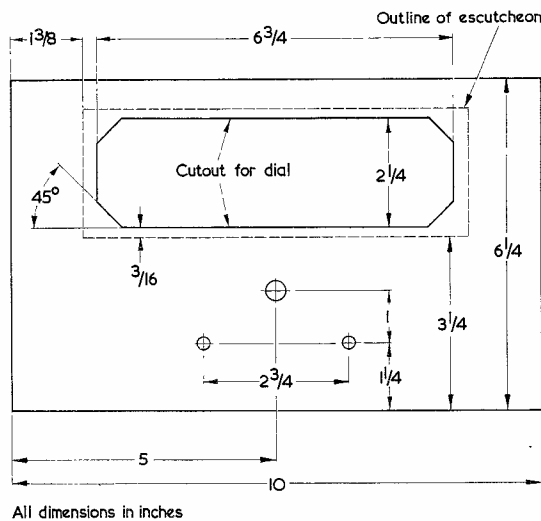

Fig. 6. Panel details

of a generator but as the intermediate frequency is not then known the procedure tends to become tedious. It is best accomplished by switching initially to medium wave and swinging C_8 through its full range. Immediately a signal is heard C_8 should be set more carefully and then, without troubling to identify the transmission, the cores of each i.f. transformer may be adjusted for maximum output. Movement of C_8 should now cause quite a few transmissions to be heard, whereupon an attempt at identifying one of them should be made (with B.B.C. stations this is most easily accomplished when Regional news bulletins are being transmitted). It will then be found that a particular transmission can be moved up and down the scale, within limits, by adjusting the core of L_3 . If the Welsh Home service is in use this should be brought to about mid-scale. Slight adjustments to L_1 core should strengthen the signal. If the tuner pointer is now moved to the high frequency end of its travel Radio Luxembourg or the West Home service may

be heard, whereupon the trimmers CT_1 and CT_3 are adjusted. At the other end of the scale the cores of these coils could be adjusted by using, say, Network Three transmissions initially. The long waveband is similarly set up by searching for the Light programme and bringing it to about mid-scale with the appropriate cores and trimmers as outlined above.

Conclusion

With the tuner aligned, trimmers and cores are scaled and the a.g.c. system checked as mentioned earlier. The tuner is now ready for use and merely requires housing. The method used will depend largely upon individual need and, as the unit might well be built into an existing equipment cabinet, etc., the simple panel section shown in Fig. 6 is intended only to provide the drilling detail for control knobs and escutcheon. The overall dimensions of the panel are, however, sufficient for it to form the front panel of a separate case.

General Coverage Communications DOUBLE SUPERHET Receiver

By Frank A. Baldwin, A.M.I.P.R.E.

Last month the circuit of the receiver was described in detail. In this concluding article the components used are discussed and the construction methods outlined

A GOOD COMMUNICATIONS RECEIVER IS VIRTUALLY just as good as its components will allow, other considerations being equal, and it is therefore of little use using or specifying inferior, or so-called "surplus" components if maximum results are to be obtained. From the components list (published last month) it will be noted that only the latest and best types of components have been specified, out-of-date or older types being of little use in a modern design.

Components

The dial and drive conforms to modern communications receiver design in that it has a large

horizontal scale (to which the writer has added two 6.3V bulbs and assemblies, thus illuminating the scale from the sides). The scale itself is so arranged that it may be self-calibrated over five differing frequency ranges if so desired, although only three ranges are catered for with the coil turret specified. The main pointer has a horizontal travel of some 7in and a circular vernier scale comprising the mechanical bandspread, this latter scale being marked with 100 divisions and rotating five complete times for one single traverse of the main pointer. This bandspread scale, read in conjunction with the main pointer, will provide a total bandspread of some 500 divisions, the scale always being set at

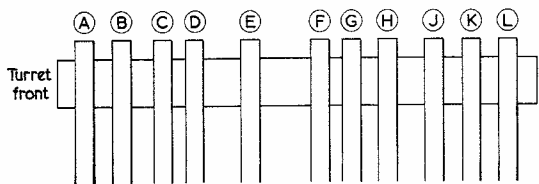

Fig. 3. The coil turret contacts

zero when the main pointer is set at either 100, 200, 300, 400 or 500. No backlash is apparent and it is therefore an easy matter to calibrate the scale and to return at any time to the exact frequency required. This latter facility is, of course, a cardinal feature in the practical application of a communications receiver. A receiver which, although perfectly sound electrically, has an inferior dial with inherent backlash, or with a cramped scale or insufficient drive reduction, is virtually useless from the practical point of view.

The dial is gear driven and flywheel loaded, thereby producing a smooth and positive drive with a reduction ratio of 110 to 1.

The directly calibrated dial is for several reasons to be preferred over that of the old circular numbered dial which, even when fitted with a vernier block, suffers from the great disadvantage that separate graphs must be maintained for each individual range and frequent reference to these must be made during the periods of operation. Other available dials were considered for this design but they had the disadvantages of (1) insufficient reduction—10 to 1 being the most common—(2) not being horizontal, or (3) not being gear driven.

It was considered most desirable to include a manufactured coilpack as against one of the home

constructed variety for the reasons that (a) the manufactured coilpack tends to be much more efficient, (b) the final results of individually constructed receivers would tend to be standardised with that of the prototype, (c) the connections are simply arranged as shown in Fig. 1 (published last month), and (d) the frequency ranges are largely standard.

Of the few coil packs available to home constructors it was thought that the one specified was ideal for the present purpose. Only three short

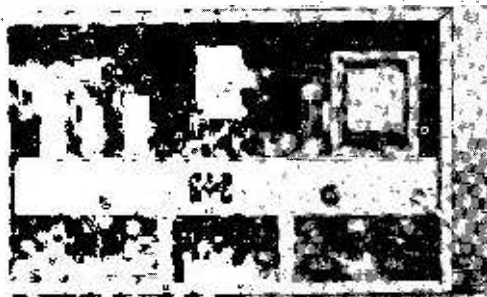

Rear view of the receiver within the cabinet. It will be noted from this that the coil turret is completely screened from the remainder of the wiring. On the rear of the chassis, at left, is the aerial input; centre, speaker output and right, fuseholder and mains input

wave ranges are included on the turret although it is a simple matter to obtain a further two ranges, where these are so desired, and add them to the existing turret. These latter ranges are those for the medium and long waves.

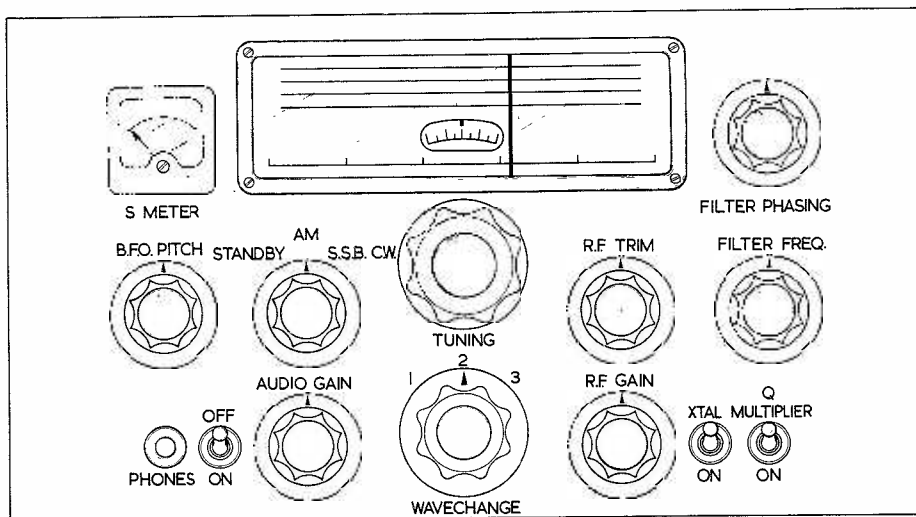

Fig. 4. The layout of the front panel

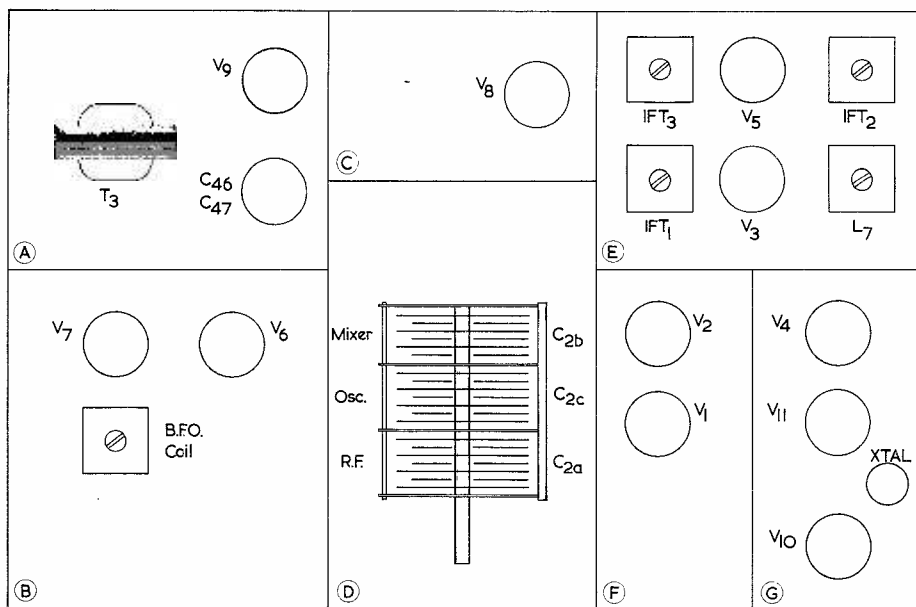

Fig. 5. Plan diagram of the chassis deck

A rotary coil turret was considered to be much more efficient than a pack employing a yaxley wave-change switch since the latter type often exhibits appreciable losses within the switch itself, particularly after the switch has been in constant use for a period of time. With the turret specified, silver plated spring contacts are employed and only one set of coils is switched into circuit at any one time, the remainder being physically far removed from the tuned circuit. This being so, no interaction is caused between individual coils of the pack. Additionally, each coil section, when switched into circuit, is adequately screened from the remainder and thus the r.f., oscillator and mixer coils of any one waveband are entirely segregated. The range of the coilpack is as follows: Range 1, 1.5 to 4 Mc/s;

Range 2, 4 to 12 Mc/s, and Range 3, 10 to 30 Mc/s.

All the capacitors and resistors are quality components, most of the capacitors being of Mullard manufacture, these being completely sealed and impervious to damp as well as being tropicalised and therefore unaffected by any reasonable amount of heat. The resistors are, in the main, of 5% tolerance and of $\frac{1}{2}$ watt rating.

The mains and output transformers are both adequately rated for the design, the mains transformer itself being specially made for inclusion in this receiver. The output transformer is physically small in order that it may fit comfortably into the layout adopted and because, in a communications receiver at least, high audio quality is not, generally speaking, required—the accent being on communications and not near hi-fi results.

The chassis and cabinet, the latter having a blue hammer finish, is known as a "free deck" type. This type of chassis confers several advantages over the more conventional type in that the deck itself is composed of several aluminium plates, each plate containing one or more sections of the circuit. For this reason, (a) later additions and/or modifications are easily carried out since only a small part of the chassis, if any, has to be scrapped; (b) extra rigidity is imparted to the chassis deck as a whole in that each plate is screwed to an underlying screen, thereby avoiding chassis "whip" under the weight of components; (c) each section of the circuit is capable of being almost completely constructed outside the main receiver frame, and (d), consequent upon (c), the whole receiver may easily be compactly constructed.

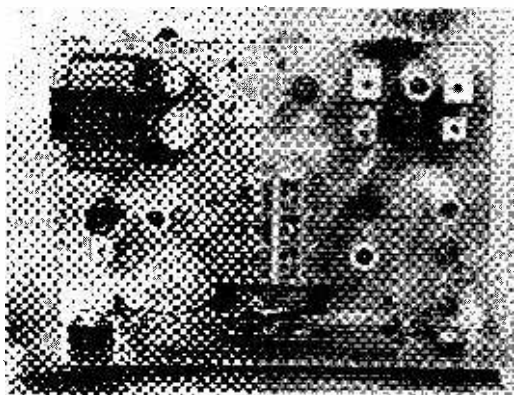

Above-chassis view of the receiver. (Compare with Fig. 5)

Construction

The illustrations and diagrams clearly show the general plan of layout and the positions of the main components. Fig. 2 (published last month) gave details of the valveholder screens. These should be earthed to an adjacent chassis tag so that all earth returns associated with any particular stage may be made to them, the components being mounted vertically from the valve tags to the screen. Since all stages are wired up outside the main chassis in sub-assembly form, this becomes a simple matter. By reason of this technique, earth returns are kept short and the chassis connections for any one stage are (in the main) made at only one point—where the earthed tag connected to the valveholder screen is secured to the chassis. In this manner, circulating currents in the chassis are largely obviated and this considerably assists with respect to the overall stability of the design. In addition, interaction and other undesirable couplings between the various anodes and grids are eliminated. The writer obtained a prolific supply of the screen material from an empty drinking chocolate tin which was opened out with the aid of a pair of tin snips, the metal being cleaned with petrol and then cut to size as shown in Fig. 2. Care should, however, be exercised to avoid cuts from the sharp edges of the tin plate.

Fig. 3 shows the connections to the coil turret and these correspond to those shown in the circuit of Fig. 1.

The majority of the connections from one stage to the other are taken through the interstage screens via small polythene leadthrough components, these

consisting of an inner continuous wire surrounded by the polythene insulation—the latter being force fitted into holes drilled into the screens. Small rubber grommets could, of course, be utilised if so desired. Grommets are, of course, used for the more bulky interstage connections such as the aerial input, volume control and phone jack wiring, and so on.

Fig. 4 shows the layout of the front panel and Fig. 5 that of the chassis. Chassis A is for the power supply; B the detector/a.g.c. and product detector/b.f.o. stages; C the output stage; D the coil turret and main tuning capacitor; E the second frequency changer and i.f. stage; F the r.f. and mixer/oscillator stages; and G the 100 kc/s crystal standard, Q multiplier and voltage stabiliser.

All connections to the turret are brought through the under-chassis screening by means of the polythene leadthroughs, these being soldered at one end direct to the turret tags and, at the other end, direct to the various components and wiring, etc. Some planning is required to ensure that all interstage screens have been drilled with their respective leadthrough holes at the correct points before assembly of the pre-assembled individual chassis.

Chassis D should be assembled, prior to fitting to the main chassis frame, the turret being secured on the underside and the 3-gang capacitor on the upper side, the latter being spaced away from the deck by metal tubular spacers $\frac{3}{4}$ in long (two to each leg) through each of which is fitted two long 2BA bolts. Spacing is required in order that the spindle of the capacitor, when finally fitted with the flexible

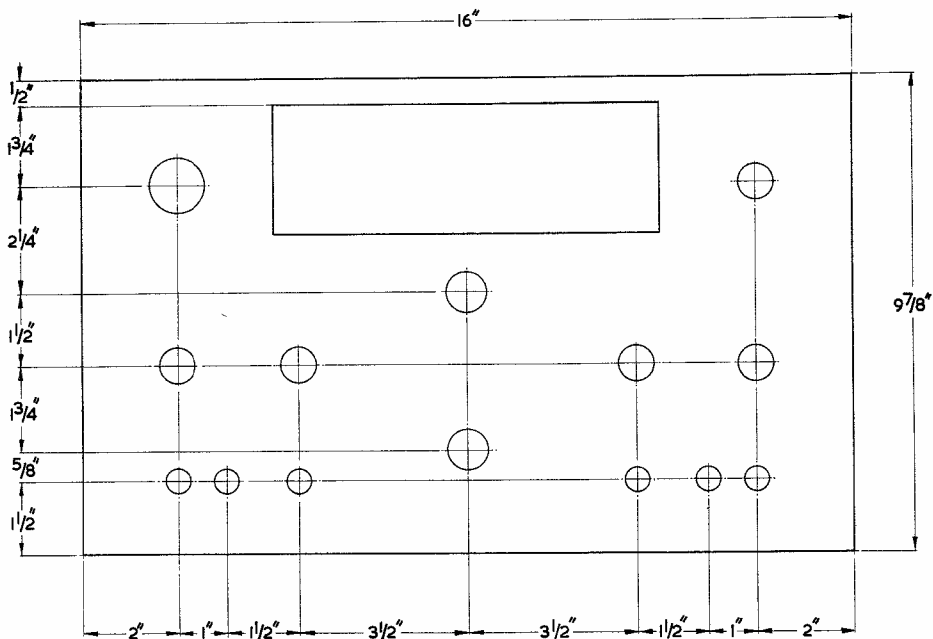

Fig. 6. Front panel drilling dimensions. A template is provided with the dial

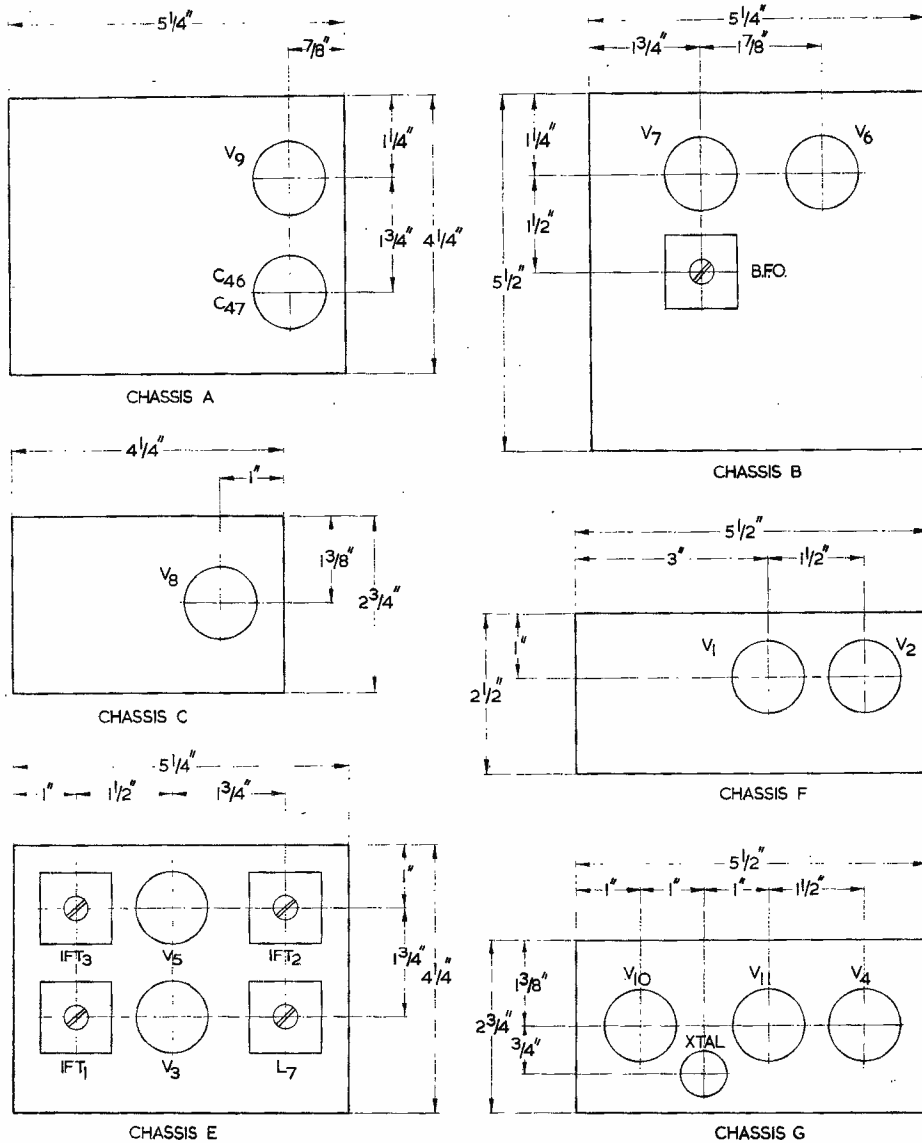

Fig. 7. Drilling dimensions of the various sub-assembly chassis

coupler, will accurately mate with the spindle of the dial drive mechanism. The leads from the capacitor should be taken through the deck via small rubber grommets. The remainder of the turret connections should be made with the side member between the r.f. and mixer/oscillator stages temporarily bolted to chassis D. Once the wiring of this sub-assembly is completed, it can be permanently bolted to the chassis frame.

Note from Fig. 5 that the mains transformer is fitted above the chassis deck. The l.f. choke is mounted immediately below. The smoothing capacitors are contained in a single metal can and the

5-way tagstrip (see Fig. 8) is fitted to the holding bolt of this component. The fuse is mounted on the rear member of the chassis frame and the a.c. mains input lead is fed through the large rubber grommet also fitted to the same member. The smoothing capacitors are secured by their associated clip mounted on the underside of the chassis, the component itself protruding through the deck for about half of its total length. The 5-way tagstrip is mounted vertically by bending the earthed tag prior to bolting to the capacitor holding bolt. Connections to this tagstrip are self-explanatory.

The aerial input lead employs coaxial cable, the

outer metal braiding of which should be connected to chassis at both ends. This also applies to the other lengths of coaxial cable shown in the circuit diagram.

All heater wiring (twisted pair) should be placed well away from the tuned circuit wiring, tucked neatly alongside the interstage screens and as near the undersides of the various chassis as possible. This will considerably assist in preventing induced 50 c/s mains hum becoming prevalent.

Figs. 6 and 7 show the front panel drilling dimensions and those of the individual chassis respectively.

Coil Turret

The coil turret used in the prototype has been somewhat modified by the addition of seven 3-30pF concentric trimmers. As received, the turret is fitted with two such trimmers (Range 2), it being intended that the constructor should add three such components on the three-gang tuning capacitor itself for the correct alignment and tracking of Range 3. The writer preferred to fit *each* coil with such a trimmer and this is easily carried out whilst the pack is mounted within the chassis assembly by careful rotation of the turret spindle, the trimmers being soldered direct to the coil connections. The extra trimmers required are not listed in the components list.

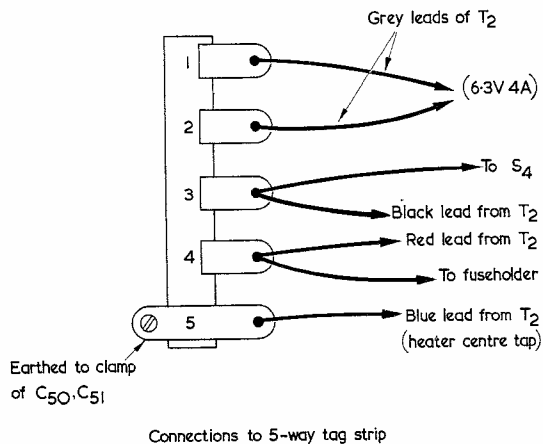

Fig. 8. Connections to the 5-way tagstrip secured under chassis A

Lining-up details for the turret are provided by the manufacturer and will therefore not be repeated here. Other lining-up procedures follow standard practice.

(conclusion)

Kit Review

Full Coverage F.M. Transistor Tuner

TO DATE, F.M. TUNER UNITS DESIGNED EXPRESSLY for construction by the home hobbyist have been, in the main, of the valve variety, but a new departure—just announced by Henry's Radio Ltd. (see advertisement pages)—is a design for a fully transistorised f.m. tuner.

The unit as such, see illustration, is assembled on a printed circuit board, this considerably assisting with respect to compactness, constructional time involved, ease of assembly and the obviating of wiring errors. The size of the printed circuit board is only some $3\frac{1}{4} \times 3 \times 1\frac{1}{8}$ in, thereby making the inclusion of the unit into an existing a.f. amplifier an easy matter.



The tuner has a frequency coverage of 86 to 110 Mc/s, the tuning being effected by a two-gang 15+15pF variable capacitor with slow motion drive.

Operating on a 9 volt miniature battery, the tuner draws some 9mA under normal signal conditions.

Circuit

This is shown herewith complete with component values, and it will be seen that the line-up consists of r.f. stage AF114; mixer/oscillator AF115; 1st i.f. stage AF116; 2nd i.f. stage AF116; 3rd i.f. stage AF116. There are also three diodes; D₁ and D₂ in the ratio detector circuit and D₃ in the a.g.c. circuit.

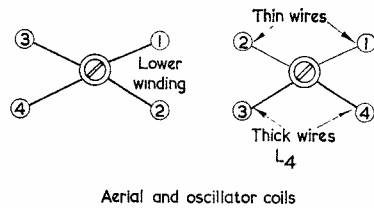
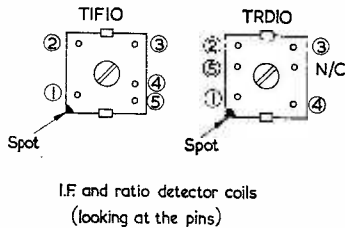
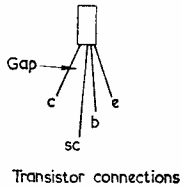
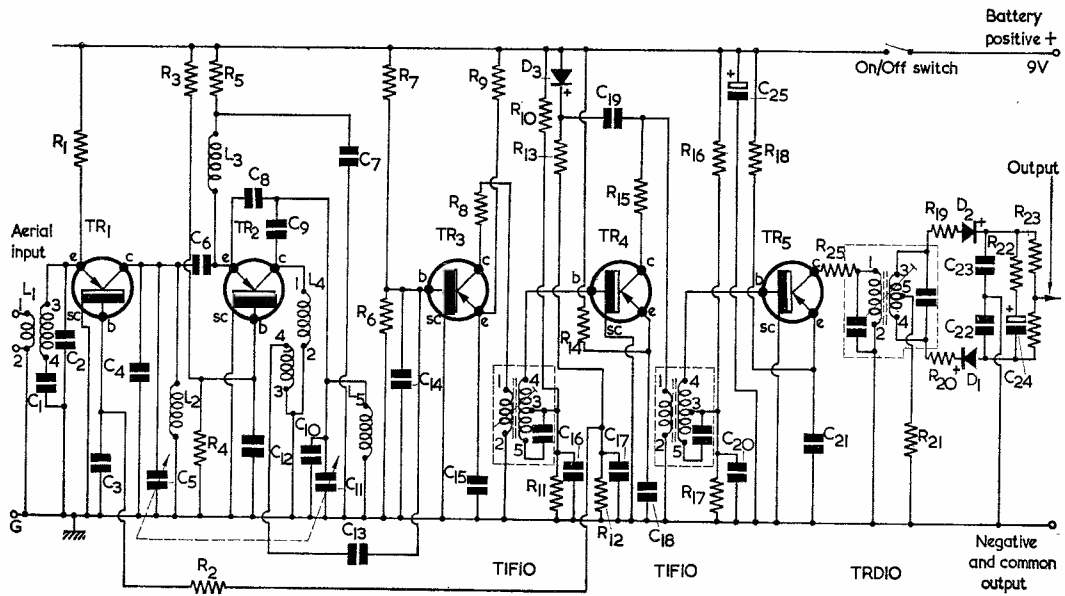

Components List

Resistors (all $\frac{1}{8}$ watt)

R ₁	470Ω
R ₂	1kΩ
R ₃	1.5kΩ
R ₄	10kΩ
R ₅	1.8kΩ
R ₆	15kΩ
R ₇	5.6kΩ
R ₈	220Ω
R ₉	1kΩ
R ₁₀	2.7kΩ
R ₁₁	10kΩ
R ₁₂	270kΩ
R ₁₃	47kΩ
R ₁₄	1kΩ
R ₁₅	220Ω
R ₁₆	2.7kΩ
R ₁₇	10kΩ
R ₁₈	1kΩ
R ₁₉	220Ω
R ₂₀	220Ω
R ₂₁	100Ω
R ₂₂	1kΩ
R ₂₃	10kΩ
R ₂₄	10kΩ
R ₂₅	220Ω

Capacitors

C ₁	15pF
C ₂	39pF
C ₃	470pF
C ₄	10pF
*C ₅	15pF
C ₆	5pF
C ₇	470pF
C ₈	4,700pF
C ₉	39pF
C ₁₀	10pF
*C ₁₁	15pF
C ₁₂	0.001μF
C ₁₃	33pF
C ₁₄	100pF
C ₁₅	0.02μF
C ₁₆	0.01μF
C ₁₇	0.02μF
C ₁₈	0.02μF
C ₁₉	10pF
C ₂₀	0.01μF
C ₂₁	0.02μF
C ₂₂	0.001μF
C ₂₃	0.001μF
C ₂₄	4μF, electrolytic, 30V wkg
C ₂₅	64μF, electrolytic, 12V wkg

Printed Circuit Boards
(Henry's Radio Ltd.)

Semiconductors

TR ₁	AF114
TR ₂	AF115
TR ₃	AF116
TR ₄	AF116
TR ₅	AF116
D ₁	OA79
D ₂	OA79
D ₃	OA79

The r.f. stage (TR₁) operates in the common base mode with a tuned collector circuit (L₂ C₅), the incoming signal from the aerial being applied to the emitter via the secondary winding of L₁. A.G.C. is applied to the base of this stage via R₂.

The mixer/oscillator TR₂ also operates in the common base mode, and it has drift-free characteristics.

The three i.f. stages (TR₃, TR₄, TR₅) all operate in the common emitter mode at an i.f. frequency of 10.7 Mc/s.

A.G.C. voltage is derived from the potential divider network (R₁₂, R₁₃, D₃) and is applied to the r.f. stage only.

The tuner circuit terminates in the ratio detector stage around D₁ and D₂.

Output from the r.f. stage is fed via C₆ to the emitter of TR₂, a supply potential being fed to the mixer/oscillator via R₅ and the r.f. choke L₃, these being decoupled to chassis via C₇.

The oscillator coil L₄ is tuned by the second half of the 15pF variable capacitor C₁₁ with the fixed capacitor C₁₀ in parallel. C₈ and C₉ provide the feedback coupling to the emitter.

The two i.f. stages operate in conventional manner the output from TR₅ being applied, via R₂₅, to the ratio detector coil primary. Detection is carried out by the diodes D₁ and D₂, the outputs of which are applied to the stabilising and a.f. circuit network.

Inductors

L ₁ , 3, 5	type FMT (Henry's Radio Ltd.)
L ₂	(r.f. coil) type FMT (Henry's Radio Ltd.)
L ₄	(Osc. coil) type FMT (Henry's Radio Ltd.)
IFT _{1, 2}	type TIF10 (Henry's Radio Ltd.)
Ratio Discriminator	(type TRD10) (Henry's Radio Ltd.)

*Two-Ganged variable, air spaced.

Also shown with the circuit diagram are the connections to the transistors, i.f. transformers and ratio detector coils, together with those for the aerial input and oscillator coils.

This compact and efficient f.m. tuner unit will undoubtedly fulfil a long felt want in the home constructor market. It is ideal for those who require quality reception of the B.B.C. programmes and, in conjunction with a suitable a.f. amplifier, should give reproduction which leaves nothing to be desired.

Construction

From the illustration it will be noted that the tuner unit is composed of two printed circuit boards on each of which the components are directly mounted. Each printed circuit board is suitably inscribed with a "legend" thereby making the assembly an easy and mistake proof matter.

The two boards are mounted at right angles to each other and are permanently joined together by soldering at the appropriate point.

The variable tuning capacitor and associated coils together with TR₁ and TR₂ are mounted on the vertical board whilst the i.f. strip is mounted on the horizontal printed circuit board, the whole making a compact and neat assembly.

Once completed, the assembly is capable of being secured inside a cabinet either to an existing chassis by means of holes provided through the horizontal board or by three threaded holes through the front frame of the variable capacitor.

H.M.S. *Leander* Tests Variable Depth Sonar

H.M.S. *Leander*, Britain's newest frigate, tested the anti-submarine detection device known as Variable Depth Sonar during recent sea trials.

This device consists of a towed sonar dome which can be lowered to considerable depths, so enabling the sonar beam to be transmitted below the reflecting temperature layers which often impede the passage of sonar transmissions from a hull-mounted set. It was developed in Canada by EMI-Cossor Electronics Ltd. in conjunction with the Canadian Defence Research Establishment.

Until the advent of this device, a submarine was able to lie below certain layers of water which, because of their temperature variation, reflected the sonar beam back towards the surface. The submarine could not, therefore, be detected.

Leander class frigates have a specially designed well in the after part of the ship to house the heavy lowering and hoisting equipment and the towed body when it is inboard.

Variable Depth Sonar is being generally fitted in the Royal Canadian Navy, and trials in Canadian ships have proved very successful. The Royal Navy is in the process of fitting it in several modern ships for trials and evaluations.

An introduction to . . .

COLOUR TELEVISION

By J. R. DAVIES

PART 7

IN THE PRECEDING SIX ISSUES WE HAVE EXAMINED, in some detail, the more important features of the N.T.S.C. colour television system. In this concluding article we shall briefly consider some of the advantages and weaknesses in the N.T.S.C. system, after which we shall carry on to the more recently introduced SECAM system.

The N.T.S.C. System—Advantages and Weaknesses

The N.T.S.C. colour system was introduced to the American public in late 1953, and it represented the results of an exceptional level of research and development by the commercial manufacturing companies—including, notably, R.C.A.—in that country. The system is characterised by its extremely ingenious approach to the problem of transmitting acceptable colour information within the same bandwidth as is employed by a monochrome transmission of equivalent luminance resolution.

The main advantages of the N.T.S.C. system derive from its technical specifications. The system is such that a colour transmission may be presented, as a monochrome picture, by a conventional black-and-white receiver. Also, an N.T.S.C. colour receiver may reproduce monochrome transmissions, which it then presents in the form of a black-and-white picture. By means of frequency interleaving, all the colour information is transmitted within the same passband as is required by a monochrome transmission. Further, the use of the IQ chrominance information system makes it possible for the colours that the eye can discriminate most readily to be reproduced at a higher resolution than the colours for which the eye has least discrimination. The fact that the N.T.S.C. system is basically practicable is demonstrated by the fact that it has been successfully used in America for a number of years and that it has now been adopted in Japan.

Despite these advantages, there has been a considerable sales resistance in America to N.T.S.C. colour television, and it is only in recent years that sales of colour receivers have started to mount. The situation commenced to improve in 1961, when about 100,000 receivers were sold in the U.S.A., and it was anticipated that more than twice this figure would be sold in 1962. There seems little doubt that the early low sales were due to the com-

plexity of receiver design, and that the system presented difficulties both to the service engineers, who installed and maintained the receivers, and to the viewers, who became confused by the functions of some of the controls. Receiver design has, of course, improved considerably since the inception of the N.T.S.C. system, and such improvements will naturally be reflected in terms of simpler maintenance and operation, and in increased sales.

It should be added here that this discussion is not intended to include the colour cathode ray tube itself; although it is pertinent to state that difficulties in early receivers with purity and convergence may well have contributed to sales resistance. The same presentation device as is used for the N.T.S.C. system will need to be employed with any other colour television system.

The complexity of N.T.S.C. receiver design, particularly in the earlier receivers, is almost entirely due to the use of the quadrature-modulated chrominance subcarrier. Because the hue reproduced by the cathode ray tube has a direct relationship to the phase of the subcarrier, it is necessary to employ, in the receiver, an oscillator having a phase tolerance of, preferably, several degrees only. A further complication is the use of IQ signals, which results in complicated matrix circuits in the receiver in order that the original colour-difference signals may be reclaimed. It should be added that the IQ technique does not appear to have been successful in practice, because recent receivers demodulate on axes which are removed from the IQ axes. Such receivers are simpler and more reliable than IQ receivers, but they restrict the chrominance information to a bandwidth which is equal to, or just slightly greater than, the Q bandwidth. If receivers of this nature are to represent standard practice, there seems to be little point in transmitting the I signal at its enhanced bandwidth, because the receiver restricts the I resolution to the same level as the Q resolution. It could be argued from this that there is no point in using the IQ technique at all. An equivalent amount of chrominance information could be transmitted on axes which would simplify receiver design, such as, say, the R-Y and B-Y axes.

The dependence of chrominance hue information

on subcarrier phase also raises problems in the transmitter, and in inter-transmitter network links. Equipment and links which are capable of handling monochrome signals quite adequately are useless for N.T.S.C. colour signals if they introduce any errors in chrominance subcarrier phasing. Indeed, the tolerance on subcarrier phase angle from an N.T.S.C. transmitter is given, at present, by the wide figure of $\pm 10\%$. Such a tolerance represents a large shift in hue rendering at the receiver. All current N.T.S.C. colour television receivers have a hue control to take up subcarrier phase discrepancies in the receiver (and, presumably, the transmitter) and it is reported that non-technical viewers become confused about the operation of such controls.

This brief review of the weaknesses of the N.T.S.C. system, particularly with respect to the phasing problems in the quadrature-modulated chrominance subcarrier, should not be looked upon as presenting an excessively gloomy view. Whilst the shortcomings should be realised, they should not be over-emphasised. The N.T.S.C. system represents a perfectly sound method of transmitting and reproducing colour television signals, and its capabilities have been proven in a nation-wide public service over a large number of years.

The SECAM System

An alternative colour television system, which is capable of producing colour pictures comparable to those given by N.T.S.C., is the SECAM system. The SECAM system is based on many of the principles employed in the N.T.S.C. system, and has been described as a logical step forward from that system.

The SECAM system was conceived by Henri de France, and was subsequently developed by the *Compagnie Francaise de Télévision*. Engineers in other countries have carried out further development in collaboration with C.F.T. Notable amongst companies interested in the system is the British General Electric Company, which announced its decision to collaborate with C.F.T. in 1961, and which demonstrated N.T.S.C. and SECAM pictures to the public during the Radio Show period of that year. *

Since the SECAM system has not, at the time of writing, been established against firm specifications in a public broadcasting service, it is not intended to describe it here in considerable detail. Instead, a broad outline of its operation in its present state of development will be given, together with a brief review of its potential advantages.

In the SECAM system, luminance information is transmitted over the full video bandwidth in the same manner as occurs with the N.T.S.C. system. A chrominance subcarrier is also employed, but it functions in an entirely different manner to the chrominance subcarrier in the N.T.S.C. system. With the SECAM system, the subcarrier carries one

* The author is indebted to the General Electric Company, who have made available to him their Communication No. 1052, *New Developments in the SECAM Colour Television System*, by G. B. Townsend. Much of the information given here is taken from this paper.

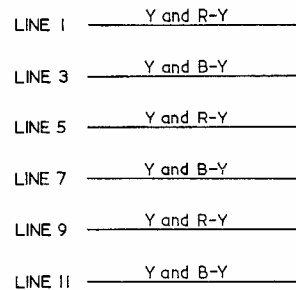

Fig. 40. The information transmitted during successive lines in the SECAM system. This process continues throughout the scanning period and from field to field

set of chrominance information (the R-Y signal) for the duration of one line of the picture, and a second set of chrominance information (the B-Y signal) during the next line of the picture. On the following line, the subcarrier carries the R-Y signal once more. The process carries on in this manner continuously, and it is illustrated in Fig. 40. In this diagram, line 1 is shown as being made up of the luminance signal, Y (which is transmitted on the vision carrier), and the R-Y signal (which is transmitted on the subcarrier). Because the picture is interlaced, the next line is line 3 (line 2 appears in the succeeding field) and this is made up of the Y signal and the B-Y signal. Line 5 follows, and we see that the R-Y signal appears once more. This sequence is carried on throughout the scanning process from field to field.

Since the chrominance subcarrier handles one signal only instead of two, there is no necessity to employ quadrature modulation. The subcarrier can, instead, be amplitude modulated or frequency

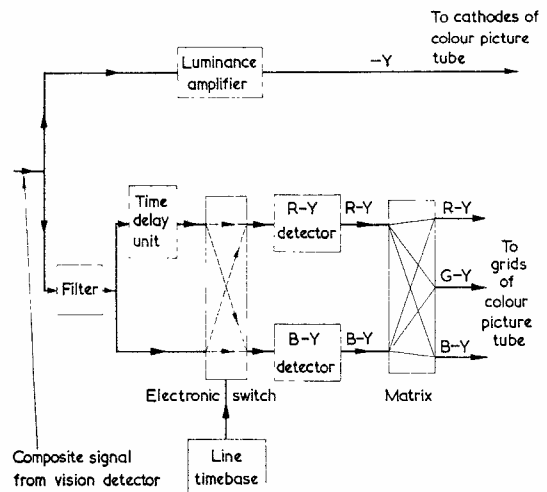

Fig. 41. Block diagram illustrating the chrominance stages in a SECAM receiver. The filter passes the range of frequencies which appear about the chrominance subcarrier

modulated by familiar processes, whereupon demodulation at the receiver involves the use of circuits which are simple and non-critical. There is no necessity to transmit a colour burst signal or to employ a synchronised local oscillator at the receiver for carrier reinsertion, nor is there any need to ensure accurate phase relationships in the receiver demodulator circuits. Further, the need for complex matrixing is obviated, since the chrominance information is carried by R-Y and B-Y signals, which are immediately available in this form after demodulation.

In order that a colour picture may be reproduced by the cathode ray tube its guns must be modulated, throughout each line, by the Y signal, the R-Y signal, the B-Y signal, and the G-Y signal. In the SECAM system the R-Y and B-Y signals are transmitted sequentially (i.e. in sequence), whereupon it becomes necessary to employ circuits in the receiver which will produce an R-Y and B-Y signal for every line. The G-Y signal may then be reclaimed from these R-Y and B-Y signals.

Fig. 41 gives a block diagram illustrating the basic steps involved in handling the SECAM signal at the receiver. The composite video signal from the vision detector (or from a common video amplifier) is applied to a luminance amplifier, which deals with the luminance signal in conventional manner and feeds it to the cathodes of the colour picture tube. The chrominance information appears at the vision detector as a band of frequencies on either side of the subcarrier, and this band of frequencies is extracted by a suitable filter. The chrominance signal now consists of the subcarrier modulated by R-Y information on one line and by B-Y information on the following line. This signal is next applied to two inputs of an electronic switch. It is applied to one input directly, and to the other input by way of a time delay unit. Also applied to the switch are control pulses derived from the line timebase.

The time delay unit delays the signal applied to it by a period which is exactly equal to one line cycle. Thus if, during one line period, we feed an R-Y signal into the delay unit, that R-Y signal will reappear at the output of the unit exactly one line period later.

In Fig. 40 we saw the signals which appear on lines 1 to 11, and we shall now carry on to see how the information on these lines is handled by the electronic switch of Fig. 41. We shall commence with line 3. This line carries the B-Y information, and the electronic switch causes this signal to pass direct to the B-Y detector. However, during line 1, the R-Y signal was fed into the time delay unit. In consequence, we now have the R-Y signal emerging from the delay unit, and it is delayed by exactly one line. The electronic switch causes this delayed R-Y signal to be fed to the R-Y detector. It must be remembered that, at the same time as the R-Y signal is emerging from the time delay unit, the B-Y signal on line 3 is going into it.

We now reach the end of line 3. Line flyback takes place, and a pulse from the line timebase

causes the electronic switch to transpose its inputs. Line 5 commences. Line 5 carries R-Y information, and the transposed electronic switch causes this signal to be fed directly to the R-Y detector. At the same time the B-Y signal from line 3 is emerging from the time delay unit, and the transposed electronic switch passes this to the B-Y detector. Whilst the B-Y signal emerges from the delay unit, the R-Y information on line 5 is going in.

Line 5 now comes to an end, whereupon we have line flyback once more. The pulse from the line timebase causes the electronic switch to transpose inputs once more, whereupon it reverts to its previous state. Line 7 commences, and the B-Y signal it carries is passed, by the electronic switch, direct to the B-Y detector. The R-Y information on line 5 is now emerging from the time delay unit and it is passed, by the electronic switch, to the R-Y detector. At the same time, the B-Y signal on line 7 is being fed into the delay unit, for use during line 9.

This process carries on continuously, and it results in R-Y and B-Y signals being continually fed to the matrix of Fig. 41, despite the fact that these signals are only transmitted on alternate lines. The G-Y signal is reclaimed from the R-Y and B-Y signals in the matrix, and the three colour difference signals are then fed to the grids of the colour picture tube.

In any one line of the reproduced picture, one of the colour-difference signals corresponds to the colour information in the preceding line. Because of this, there is a loss of colour resolution, with the SECAM system, in the *vertical* sense. In the N.T.S.C. system, the colour information has low resolution in the horizontal sense, but its resolution in the vertical sense (from one line to the next) is equivalent to its luminance resolution. The decrease in vertical resolution given by the SECAM system should, therefore, offer no significant reduction in picture quality, when compared with the N.T.S.C. system. It involves a loss of resolution in the vertical sense when a loss of resolution is already considered acceptable in the horizontal sense.

The time delay unit employed in a SECAM receiver can be described as a "memory". Another feature of the SECAM system is the fact that the colour difference signals are transmitted sequentially. It is from the French phrase "*séquentiel à mémoire*" that the term SECAM has been coined.

Synchronising the Electronic Switch

In order that the electronic switch of Fig. 41 may route the R-Y and B-Y signals from the vision detector and the delay unit into the correct detectors, it is necessary for it to keep in step with the input signal. The switch is changed from one state to the other by a pulse from the line timebase and, if it were out of step, it would feed R-Y signals into the B-Y detector and vice versa. Since once the switch has been synchronised it should stay in step indefinitely (assuming that the line timebase is always in synchronism with the received signal), it is only necessary to check its condition at occasional

intervals.

This process may be carried out by transmitting a colour recognition signal at the end of each field synchronising period. The transmitted signal could correspond to a particular polarity in one colour-difference signal, whereupon incorrect switching would cause an output of reversed polarity to be given from the matrix following the R-Y and B-Y detectors. This reversed polarity signal could cause an extra pulse to be fed into the electronic switch, which would then be brought back into correct step again.

The Subcarrier

The SECAM subcarrier may appear, as in the N.T.S.C. system, within the video passband of the transmitter. It could have the same frequency as an N.T.S.C. subcarrier.

In earlier development the subcarrier was amplitude modulated, but this was later changed, with a considerable improvement in performance, to frequency modulation. The R-Y and B-Y signals go negative as well as positive, whereupon a negative modulating signal causes the carrier to be shifted to one side of its central frequency, and a positive modulating signal causes the carrier to be shifted to the other side. A suitable maximum subcarrier deviation in a 625 line system would be 750 kc/s on either side of central frequency.

At the receiver, the frequency modulated subcarrier signal may be demodulated by conventional f.m. detectors, and no reference frequency generators or synchronous detectors are required. Also, there is no necessity for a hue control.

A small amount of manipulation of the colour-difference signals takes place at the transmitter, this consisting of a low frequency pre-emphasis. This pre-emphasis may be removed at the receiver with the aid of a simple resistance-capacitance filter.

The amplitude of the subcarrier is reduced at the centre frequency to decrease the effects of beat interference with the sound and vision carriers. The amplitude is then allowed to increase as the subcarrier becomes removed from its central position. This process ensures that a good signal-to-noise ratio is achieved for wide deviations, whilst still retaining an overall freedom from excessive beat interference.

The Time Delay Unit

The time delay unit has to delay the signal by a time equal to one line. This is a relatively long period, and it would be uneconomic to attempt to use purely electronic delaying devices. The delay unit currently employed consists of a cylinder of glass having a zero temperature coefficient, its length being some 8in and its diameter approximately 1in. The input signal is applied to a transducer at one end of the cylinder which converts the electrical signal into mechanical impulses. These arrive, delayed, at the other end of the cylinder, whereupon they are re-converted to electrical signals by way of a second transducer. There is a loss of energy in the time delay unit which has to be made good

by a subsequent amplifier. The signal applied to the delay unit is the frequency modulated subcarrier, with the result that it is unimportant if the frequency response of the delay unit is not flat-topped, since the delayed signal is applied to an f.m. detector which does not respond to variations in amplitude.

Compatibility

The SECAM system is fully compatible. A monochrome receiver may reproduce a SECAM signal in black-and-white, whilst a SECAM receiver may reproduce, in black-and-white, a monochrome signal.

The Advantages of the SECAM System

The main advantages claimed for the SECAM system are that it eradicates the complexities given by the N.T.S.C. system. A SECAM signal can be fed through transmitter network links of monochrome quality, and it does not have the same sensitivity to phasing errors as has the N.T.S.C. signal. Also, a SECAM receiver is more stable and easier to design, and its principles of operation can be more readily understood by service engineers.

The PAL System

Before concluding, mention must be made of the recently introduced PAL system, developed by Telefunken. In company with N.T.S.C. and SECAM, the PAL system has been investigated by the European Broadcasting Union in a quest for a colour television system suitable for use in Europe.

PAL is based on the N.T.S.C. system, in that I and Q signals are transmitted on a chrominance subcarrier located with the vision passband. However, whilst the Q signal is transmitted in the same manner as with N.T.S.C., the I signal is reversed in phase on each successive line. To recover the original signal, the receiver then includes an electronic switch which reverses the phase of the received I signal on alternate lines before colour reclamation takes place in the chrominance channel.

The main advantage claimed for the PAL system is that, due to the manner in which the signal is treated, errors in colour rendering due to incorrect phase of the chrominance subcarrier can be cancelled out. If, on one line, a colour signal corresponding to a positive phase error appears after the phase reversing switch in the receiver, the colour signal on the following line will have a negative phase error.

In a simple receiver working on the PAL system, the reclaimed signals are fed to the cathode ray tube in normal manner, and the eye tends to see the average between two incorrect colours in successive lines. As the incorrect colours deviate on either side of the correct colour by an approximately equal amount (and provided the errors do not correspond to more than about $\pm 7^\circ$), the eye has the impression of perceiving a single correct colour. Receivers working under this principle have been described as "People's PAL" or "Volks PAL". In more expensive receivers a time delay unit, offering a delay equal to one line, causes the I and Q signals

from the preceding line to be fed to the colour reclamation circuits in company with the transmitted I and Q signals. Errors in phase on alternate lines are then averaged out electronically, and each line of the picture appearing on the cathode ray tube screen carries averaged colours.

Due to the manner in which PAL receivers operate, a hue control is not required.

Another advantage with the PAL system is that, whereas with N.T.S.C. the I signal is transmitted

with one sideband partially suppressed, the phase reversals given with PAL result in a signal comparable with one having full sidebands. The result is an improvement in reception under certain fading conditions together with an easing in frequency response requirements in the i.f. stages and the tuner unit.

The term PAL is derived from Phase Alternation Line.

(conclusion)

CHRISTMAS CASTAWAY CONTEST



Prize: Value 15 gns.

(10 gns. cheque plus 5 gns. Book Voucher)

Consolation Prize: Value 10 gns.

(5 gns. cheque plus 5 gns. Book Voucher)

Awarded to any competitor whose entry is subsequently published

Vouchers may be exchanged for radio or other books

Although not generally known among geographers, there exists in the South Pacific a small isolated island which has the highly improbable name of Transistiana. Whilst the plant and animal life on Transistiana is typical of that existing on similar islands in that part of the world, Transistiana has an extraordinary feature which is peculiarly its own. Between two 60ft palm trees there is a hut containing a bench, a vice, a soldering iron, a full set of metal and woodworking tools, and a power supply socket which provides 240 volts, 50 c/s a.c., at currents up to 50 amps.

It has occurred to us that home-constructors who have the misfortune to be shipwrecked in the Pacific might well find themselves stranded, on their own, on Transistiana, whereupon they would be able to use their imagination and skill in building radio or electronic equipment in order to make their enforced stay both pleasant and creative. In consequence, we invite readers to send us their accounts of how they, themselves, would act if they were cast away upon this island. Each reader is allowed to have with him as many components as may be stored in a crate having internal dimensions of 4 x 3 x 2ft maximum, the weight and cost of the components being unimportant.

Entries must be written on one side of the page only, and should be sent to:

Christmas Castaway Contest,
Data Publications Ltd.,
57 Maida Vale,
London, W.9.

There is no entrance fee, acknowledgements of receipt will be sent to competitors and manuscripts not required will be returned. Name and address should be printed on each entry.

The text, together with any drawings which may be reproduced, should not take up more than approximately 1½ pages in the magazine (circuits and diagrams will be redrawn by our draughtsmen).

The winning entry will be published early next year and the closing date is 20th January, 1964. Contributions will be judged on their general approach and ingenuity, and humour will not be at all out of place. The Editorial Board's decision will be final.

We must point out that, whilst transmission and reception conditions on Transistiana are excellent, there is no point in contacting ships or aircraft in an attempt at rescue. This is because the island is so situated that no ship or aircraft has yet been able to discover it.

1963 International Radio Communications Exhibition

THE 1963 INTERNATIONAL RADIO COMMUNICATION Exhibition was again held this year at the Seymour Hall, Seymour Place, London, W.1, and as in former years, it was the occasion for radio amateurs and constructors to enjoy a "ragchew" and to inspect the latest products of the manufacturers who cater for their interests.

Several new items were on display at various stands and many well known equipments were featured, in addition to which a whole host of components of the very latest types were to be seen. The most notable new introductions were those of the Eddystone EA12 amateur band communications receiver (with optional panadapter), the K.W. Electronics Ltd. KW707 communication receiver and "Project 2000" s.s.b. transceiver, and the Minimitter Co. Ltd. TR7 1.8 Mc/s transistor mobile receiver.

Electroniques (Felixstowe) Ltd. Since the last Exhibition, this company have more than doubled their range of products, the latest introduction being that of a 1.6 Mc/s high selectivity bandpass crystal filter. The well known range of "Stabcoils", "Qoilpax", i.f. transformers, filters, chokes and detector units were to be seen and, additionally, a new range of control knobs together with a contemporary styled 2-speed slow motion full vision dial. A new comprehensive range of air wound coils ("codar goils") introduced in co-operation with the Codar Radio Co., were also in evidence as were the Codar pre-selector and communication receiver.

K. W. Electronics Ltd. It is, of course, impossible in a short review to mention everything displayed on the various stands of this company. That most notable to the writer was the new KW707 communication receiver and some details of this are given here. Designed for s.s.b., a.m. and c.w. operation, this receiver is a double conversion superhet covering the amateur frequencies from 1.8 to 29.7 Mc/s. It employs a crystal controlled first mixer and variable oscillator for the second mixer which is the main tuning control for all bands. The first i.f. is tuneable and ganged with the variable oscillator which covers the range 5,000-5,600 kc/s. Selectivity for s.s.b. reception is obtained by a 2.1 kc/s (nominal) mechanical filter and b.f.o. insertion to the product detector is crystal controlled by means of two crystals for upper and lower sideband. For c.w. performance, a half lattice filter is employed in cascade with the mechanical filter. B.F.O. injection for c.w. is by means of a separate variable oscillator. For a.m. reception, three selectivity positions are provided (1) normal passband using tuned circuits at 455 kc/s; (2) mechanical filter upper sideband and (3) mechanical filter lower sideband. Valve line-up and semi-conductors as follows: EF183 r.f. amplifier; ECF82 first mixer and crystal oscillator; 6BE6 second mixer and oscillator; 6BA6 i.f. amplifier; 6BA6 i.f. amplifier; two S35 product detector; EF91 crystal calibrator; ECL82 second audio and audio output; four DD006 h.t. rectifiers; 12AU7 "S" meter amplifier and first audio amplifier; 12AU7 carrier insertion oscillator; 6BA6 b.f.o.; 6AL5 noise limiter, ECF82 a.g.c. gate and amplifier; S35 a.m. detector; S35 a.g.c. rectifier and OA2 h.t. stabiliser.

Radio Society of Great Britain. An interesting display of home constructed equipment was featured on this stand and, among others, the writer noted the well known GDFA

communications receiver; an s.s.b. 10-80 metre transmitter by G3HRO; a 3.5-28 Mc/s linear amplifier (200W PEP at 1250V) by G6JP; a transistorised communication receiver by A. L. Mynett G3HBW together with his transistorised a.m./s.s.b./f.m./c.w. single channel transceiver (10W PEP) covering 10-160 metres. Also noted were two items by J. Glazeley BRS20533, both being constructed within 2-oz. tobacco tins. These were a 1.8-25 Mc/s transistor converter and a 2-metre transistor pre-amplifier. An item of singular practical use consisted of an enormous air-spaced variable capacitor complete with an equally enormous knob labelled—Knob Twiddlers Delight!

The Minimitter Co. Ltd. in addition to their range of converters and other products, featured the new TR7 1.8 Mc/s mobile transistor receiver and also a half lattice crystal filter unit which is capable of being fitted in place of an existing 465 kc/s first i.f. transformer.

The British Amateur Television Club had an interesting demonstration of television with the transmissions being received direct from G3NDT/T (Harrow) on 430 Mc/s; a distance of some twelve miles.

R. S. G. B. Headquarters Station. GB3RS operated on the bands 15-160 metres using a G8KW trap dipole aerial on the roof of the hall. When working over the bands 15-80 metres, a table-top transmitter running 120 watts input was used while, when radiating on the 160 metre band, a separate transmitter having 10 watts input was used. The receiver was a double superhet tuning over the amateur bands only. For the 2 and 4 metre bands, GB2VHF (a new call sign obtained specially for use at this exhibition) used a 2 metre transmitter with an input of 100 watts and a two-bay turnstile aerial together with a receiver (double superhet) having a 6CW4 nuvistor converter. On 4 metres, a separate transmitter ran 40 watts to a 4-element Yagi, the receiver being similar to that used on GB3RS with the addition of a separate converter. The whole station was built into a most impressive console and the equipment consisted of home constructed units loaned by members of the Crawley Amateur Radio Club. The members of this club are most certainly to be congratulated on the high standard of workmanship and presentation of this station which obviously represented many hours of planning and hard work.

Hammarlund Manufacturing Co. (represented by K. W. Electronics Ltd.) featured their well known receivers HQ180A; HQ145X; HQ170A and HQ100A; these being general coverage types. Those for the amateur band coverage were the HQ170A and HQ110A. The HX50 s.s.b. transmitter matches any of the receivers and the new HLX1 linear amplifier provides the operator with a completely matched and efficient station.

Green and Davis. Among other items, this company presented their 1964 2-metre equipment, the Nuvisor Converter Mk IV, and this is claimed to be the ultimate in 2-metre converters available to the radio amateur. The noise factor is 1.8 (2.55dB) and the valve line-up is as follows: 6CW4 r.f. amplifier; 6CW4 r.f. amplifier (cascode nuvistor r.f. stages) 6CW4 mixer and 6060 oscillator chain incorporating the latest

HC6/U miniature crystal at high frequency. A silicon diode together with the mains transformer and neon indicator comprise the power supply. Their CW/TX Exciter/Driver unit was also to be seen, this being a 15-20 watt 144 Mc/s unit which may be used either as a high frequency (2 metre) c.w. transmitter or as a driver for a high power 2-metre transmitter or 70 cms driver stage. Valve line-up 6060, 6060 crystal oscillator and first multiplier; ECF82 pentode section protects p.a. at 144 Mc/s whilst triode section drives p.a. at 144 Mc/s; QQVO3-10 p.a. stage.

Webb's Radio. For the writer, the new Eddystone EA12 communication receiver provided the main item of interest here. This receiver is a 13 valve double conversion superhet for s.s.b., c.w. and a.m. operation on all amateur bands from 10 to 160 metres.

A crystal controlled "front-end" and tuneable first i.f. provide high stability and a constant tuning rate at all frequencies in the tuning range. Calibration is linear and can be read to within one kilocycle when the scales are standardised against the built-in crystal calibrator. The i.f. tuning range is restricted to 600 kc/s to give adequate bandwidth on the lower frequency bands and in consequence four separate ranges are used for complete coverage of the 10 metre band. Nine ranges cover the six amateur bands in the tuning range of the receiver.

The overall performance is sensibly constant for all frequencies and a bandpass-tuned r.f. amplifier of the cascode type ensures extremely good protection against cross-modulation and blocking. The signal frequency circuits are tuned by a separate control which takes the place of the more usual aerial trimmer. A 2-1 reduction drive makes for ease of adjustment.

Continuously variable selectivity is available at the low frequency second i.f. together with a tuneable slot filter and a crystal filter for CW reception. When taking s.s.b. signals provision is made for positive selection of the correct bandwidth and the appropriate carrier insertion frequency, the latter being adjustable within fine limits by use of the b.f.o. control. This has a 5-1 reduction drive and operates with a much reduced tuning swing when used in this mode.

A normal envelope detector and series diode noise limiter are used for a.m. reception and a product detector with double diode noise clipper for c.w./s.s.b. A low-pass audio filter is permanently in circuit for c.w./s.s.b. reception but can be switched to become a sharply tuned filter when taking CW signals under conditions of severe adjacent channel interference. Valve line-up is as follows: ECC189 r.f. amplifier; ECH81 first mixer and oscillator, amplifier/doubler; EC90 first oscillator (crystal controlled); ECH81 second mixer and oscillator isolation amplifier; EC90 second oscillator (v.f.o.); EF93 first 100 kc/s amplifier; EF93 second 100 kc/s amplifier; EB91 a.m. detector and a.g.c. rectifier; ECC83 cathode follower and audio amplifier; EK90 c.w./s.s.b. detector; EL90 audio output; 150C2 h.t. stabiliser; EF94 crystal calibrator. Semi-conductors—DD006 a.m. noise limiter; DD006 c.w./s.s.b. noise clipper and DDO58 h.t. rectifier.

The writer enjoyed visiting the Exhibition and, as will be noted from the short review presented here, was particularly on the look out for newly introduced items of amateur equipment, an Exhibition such as this being the ideal occasion on which to launch such ventures.

RADIO TOPICS . . .

by Recorder

IT IS POSSIBLE THAT, BY THE TIME these notes appear in print, the European Broadcasting Union will have reported to the C.C.I.R. on the colour television system which they consider to be the most suitable for use in Europe. The choice rests between N.T.S.C., SECAM and PAL, and the task of the E.B.U. is by no means an easy one because these three alternatives give results which are, in practice, not excessively dissimilar.

Of the three systems, N.T.S.C. came first, and it has been in use in America for some ten years now. It has the main disadvantage that colour reproduction is dependent on accurate phasing of the chrominance subcarrier. On the other hand, it is backed by much production and development experience and represents, as it stands, a system which is known to be perfectly practicable. SECAM was introduced after N.T.S.C., and it overcomes the chrominance subcarrier phasing problem by transmitting only one colour per line on a frequency modulated subcarrier. And, finally, there is PAL, which is closer to the N.T.S.C. system than SECAM. By reversing the phase of the transmitted I signal on alternate lines, PAL causes errors in chrominance subcarrier phasing to be averaged out.

On the face of it, both SECAM and PAL seem to have a basic advantage in that they overcome the acute sensitivity to chrominance subcarrier phase which is the major shortcoming of N.T.S.C. Neither a SECAM receiver nor a PAL receiver requires a hue control, because (with SECAM) the system does not necessitate hue correction and (with PAL) the hue errors are largely, if not completely, cancelled out.

Yet, I wouldn't be the slightest bit surprised to learn that the E.B.U. recommends that the N.T.S.C. system be employed in Europe. And it may well be that one of the reasons for this choice is that the N.T.S.C. system has the advantage of ten years of production and development experience.

The Value of Experience

I quote this example because it highlights, in a striking manner, the considerable importance of production and development experience with respect to any intricate mass-produced item. The ironic fact about complex products sold to the general public is that you have to make a dickens of a lot of them before you can finalise your design! The back-room boys can knock up a prototype which, on its own, performs beautifully; but this is only of the "one-off" variety. The prototype has to be translated into a form which is capable of being mass-produced before manufacture can begin and, at that time, nobody can predict all the production snags which will occur until production is actually in progress. When, instead of "one-off", you've made something like "5,000-off", then you can say that you have a good idea of what the major problems are. The same applies to performance. It is impossible to accurately assess the performance of a complicated device from one sample. Engineers have to live in a very real world in which all dimensions and measurements are expressed in terms of tolerance. Tolerances have a nasty habit of building up in the wrong direction, and can well result in an uncomfortably high proportion of rejects for unsatisfactory performance when the device is in high-quantity production.

Yet again, complex devices have to stand up to normal wear and tear after manufacture and sale, as well as the effects of atmosphere and temperature. The acid test for reliability under these conditions is to make a large number of units, sell them, and see how they cope. Many large manufacturers of intricate devices keep a careful watch on their products after they have left the factory. If an unforeseen fault becomes evident after a period of time, they then modify their production accordingly.

This procedure is all aimed at making the product cheaper to manufacture and capable of working better with increased reliability. But it takes a long time for the process

to be finally carried out.

I occasionally wonder what would have happened if, at the turn of the century, somebody had developed an electric battery which was light, small and inexpensive, and which could pour out a fantastic amount of amps at a very convenient voltage. Also, that nobody had invented the internal combustion engine. By about now, our roads would be blocked with electric cars and lorries, each with its own little battery and electric motor. Let us assume that, under these conditions, somebody *now* came along with a very rough sample of what he called a "petrol engine". After he had explained that his engine operated because a piston thudded up and down a cylinder due to explosions at the top, and that the energy in the piston could only be changed to rotary movement by way of a crank-shaft, most people would have raised a polite eyebrow and wandered off to go home in their nice, smooth-running, ozone-producing electric vehicles.

A petrol engine does not, let's face it, represent the *nearest* approach to obtaining mechanical power. But it has attained its present considerable importance in our civilisation because it has the advantage of many, many years of production and development experience. Lift the bonnet of a modern car and you will see a neat little engine which offers a high degree of reliability and efficiency at low cost. But it has only got that way because, over the years, all the snags have been cleared by a process of continuous manufacture in quantity and subsequent development.

Returning to the question of colour television, some of our pundits tend to scoff at the idea that the ten years of practical experience which is behind the N.T.S.C. system represents, in any way, an advantage. They state that if a new colour system is to be introduced to Europe the system chosen should be one which offers the maximum *theoretical* advantages, even if these have not all been transformed into successful practice yet. This represents good reasoning, and most, if not all, of us will have considerable sympathy with the argument. But it is unwise, surely, to completely discount the production and development experience which has been gained by N.T.S.C. It could be stated that, if Europe were to adopt the PAL or SECAM systems, we might well find ourselves embarking on a 10 year gestation period similar to that already undergone by N.T.S.C. in the States. N.T.S.C. has now emerged as a practicable system,

with considerable production and development experience to its credit. If this fact has been taken into consideration by the E.B.U. in making their difficult choice they are exhibiting a common-sense approach which has much to commend it.

Music by Post

I'm not altogether too keen on practical jokes, because many of these tend to have a somewhat sadistic character which I find rather distasteful. At the same time I couldn't resist a chuckle when I read about a character in Owensboro, Kentucky, whose jokes are not only harmless but have a mildly Goonish flavour as well. This gentleman sends packages through the mail that are correctly packed and stamped, and which contain tran-

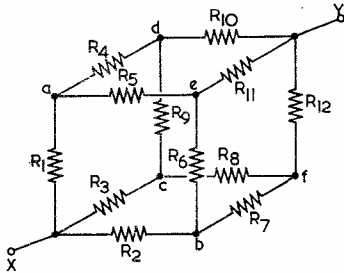

Fig. 1. The cube of resistors. If each resistor has a value of 1Ω , what is the resistance between X and Y?

sistor radios turned on at full blast. Like all good postal workers, the Post Office staff at Owensboro take these cacophonous packages in their stride, and deliver them imperturbably to their addressees.

Cube of Resistors

I would guess that readers looking at the circuit shown in Fig. 1 will react in one of three ways. They will either (1) observe it with a frown, recognising it as one of those infuriating little problems they've never got round to solving yet, (2) look upon it with the disdainful expression of one who already knows the answer, or (3) give it one of those dubious glances which indicate a complete absence of clues as to what it's all about. For the benefit of (3) I will explain that Fig. 1 is the well-known "cube of resistors" which is usually raised to torment students who are working their way through parallel and series resistor combinations. Each resistor has a value of (say) 1Ω , and the problem is to find the resistance between points X and Y, or the total current which flows when a specified voltage is applied

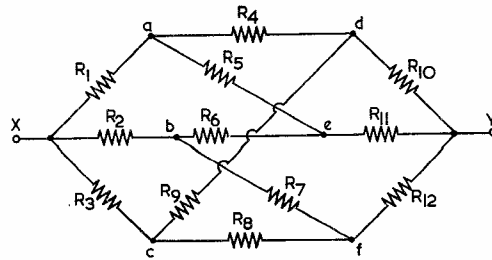

Fig. 2. The cube of Fig. 1 may be redrawn as shown here

to points X and Y.

I must confess that, until recently, I was in category (1), but I have now promoted myself to category (2) as the result of reading an item in the October issue of our lively American contemporary *Radio-Electronics*.*

The trouble with Fig. 1 is that it is difficult to isolate parallel and series resistor combinations from the cube network. It helps a little to rearrange the resistors as in Fig. 2 but, even here, things aren't really much easier. However, Fig. 2 does show the symmetry of the circuit in that R_4 joins point (a) to point (d), R_6 joins (b) to (e) and R_8 joins (c) to (f). Slant-wise, R_5 joins (a) to (e),

* Kendall Collins, "Double Grid" (in the feature "What's Your EQ?") *Radio-Electronics*, October 1963.

also in parallel, giving us $\frac{1}{2}\Omega$, whilst R_{10} , R_{11} and R_{12} offer a further $\frac{1}{3}\Omega$. Thus, the total resistance is $\frac{1}{2} + \frac{1}{3} + \frac{1}{3} = \frac{2}{3}\Omega$.

Simple, isn't it? (Once you know how.)

December Again

So we come to another December issue, with 1964 nearly upon us. And I predict that 1964 will be quite an interesting year in the field of radio and electronics.

The big event will undoubtedly be the launching of BBC-2 on u.h.f. As I visualise it, BBC-2 will not start with the same impact as occurred with ITV on Band III, because people already have two programmes to choose from and the attraction of a third programme when two are available is bound to

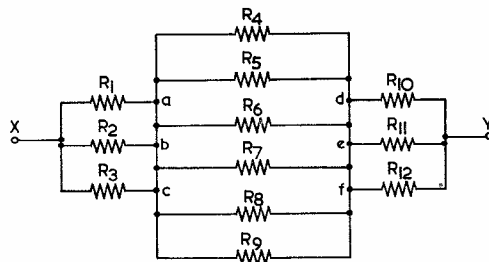

Fig. 3. Connecting points of equal potential together allows the cube to be presented in this simple form

R_7 joins (b) to (f) and R_9 joins (c) to (d). The symmetry is such (and here's the secret) that, if a voltage is applied to X and Y, points (a), (b) and (c) assume the same potential, as also do points (d), (e) and (f). The similar-potential points may, therefore, be shown connected together for purposes of calculation; whereupon we arrive at the network given in Fig. 3.

From now on it's plain sailing. All the resistors in Fig. 3 are equal to 1Ω , so that R_1 , R_2 and R_3 in parallel give us $\frac{1}{3}\Omega$. R_4 to R_9 are

be lower than the attraction of a second programme when only one is available. Nevertheless, there will be a general demand for u.h.f. reception which should build up over the year, albeit more slowly, to almost the same level as happened with Band III in 1955. There should be plenty of work for the aerial riggers!

With which comforting thought I must now add my sincere wish that you all have a Christmas which is truly Happy and Merry.

See you next year!

SUPERHET RADIO CHASSIS

These well-made chassis were made for the Government for Forces entertainment with 6K8, 6K7, 6Q7, 6V6. Choke smoothing, slow-motion tuning, printed scale, 200-550 metres.



BRAND NEW, ONLY **57/6**

Post 5/-

Cabinet with 8 in. speaker to fit **27/6**

HOOVER

ROTARY TRANSFORMERS

12V input, 500V output at 65mA or 6V input, 250V output at 75mA. PRICE **9/11**



CRYSTAL SET

Complete set of components **9/11** P.P. 1/9

With earpiece 12/11. With high resistance headphones **22/11**.

HIGH IMPEDANCE PERSONAL LISTENING EARPIECES

Suitable for all types of crystal sets and transistor sets. Complete with plug **5/11** P.P. 6d.



COMPONENTS

SMOOTHING CHOKES. 100mA, 10-20H, resistance 450 ohms. Sturdy metal case. **4/11** P.P. 2/6.

SMOOTHING CONDENSERS. TCC metal enclosed block condenser, $4\frac{1}{2}'' \times 2\frac{1}{2}'' \times 1\frac{1}{2}''$, with terminals. 8 μ F. 350V working. Suitable for cross-over units. **3/11** P.P. 1/6.

MAINS TRANSFORMER. Mains standard primary 250. 0.250V 80mA. 6.3V at 4A, 5V at 2A. Both tapped at 4V. **18/11** each P.P. 2/6

FILAMENT TRANSFORMERS. 250-250V 50 c/s primaries. 6.3V at 2A. **6/11** P.P. 1/3

OPERATORS' UNITS. A host of valuable components (block condenser, jack plug, socket, etc.). ONLY **1/11** each P.P. 9d.

PAXOLIN TAGSTRIPS (14 tags). Double way. **1/3** each P.P. 6d.

PANEL MOUNTING FUSE HOLDERS. Beautifully made, plastic sturdy construction. **2/11** each P.P. 6d.

ELECTROLYTIC CONDENSERS. 0.5 μ F. TCC. 500V working. **1/-** each P.P. 3d.

MORSE KEYS. Morse key assembly No. 8. Key with base, cover and terminals. Complete with lead, jack plug and connector. BRAND NEW. **6/11** P.P. 2/3

OCTAL MOULDED VALVE-HOLDERS. 6d., 3 for 1/3. 807 Valveholders, 9d., 3 for 2/-.

67G valveholders, ceramic moulded with screening skirt, 9d., 3 for 2/- P.P. on each 3d.

CONDENSERS. Variable condenser solid dielectric, .0005 μ F. **3/3** P.P. 9d.

TRIMMERS. 0.750pF max. **9d.** P.P. 3d.

PERSONAL CALLERS WELCOME AT OUR NEW BRANCH BELOW:

Orders from Abroad welcome



SONA ELECTRONIC CO (DEPT RCI)
BRIGGATE HOUSE, 13 ALBION PLACE, LEEDS. TEL: 34703

CONDENSERS. 50 μ F electrolytic reversible 12V working. **1/3** P.P. 3d.

1 μ F CONDENSERS. 130V working. Suitable as suppressors. **1/11** P.P. 9d. 470pF, 10% tolerance, 750V working. **7d.** P.P. 3d.

RF FIELD INDICATORS

Designed for checking the radiation from a transmitting antenna. The sensitivity can be controlled by adjustment of panel control, the antenna length, or by increasing distance from the radiator. Frequency range 1-250Mc/s. 200 μ A D.C. **69/6**

LEAD ACID ACCUMULATORS

(Unspillable)
2 volts 16 A.H. Brand new. Size 4" x 7" x 2". 4/11 each, 3 for 12/6. P.P. 3/-.

OSCILLATOR TEST SET No. 10

Enabling the equipment to be used from a telephone line, etc., 230V A.C. input having an internal F.W. H.T. supply testing unit. **37/11** EACH P.P. 7/6



PERSONAL CALLERS WELCOME AT OUR NEW BRANCH BELOW:

Terms: Cash with orders. No C.O.D. under £1.10.0.

TRANSISTOR SALE

Mullard OC44...3/11 P.P. 3d.
Mullard OC45...3/11 P.P. 3d.
Mullard OC71...2/11 P.P. 3d.
Mullard OA81...1/11 P.P. 3d.
Ediswan X020 Germanium diodes1/11 P.P. 3d.
Transistor Holder, 3 Pin 11d. each P.P. 3d.

MICRO ALLOY TRANSISTORS

Mat 100..... 7/9
Mat 101..... 8/6
Mat 120..... 7/9
Mat 121..... 8/6
Above MATs Postage Paid
Ferrite Slab Aerials, suitable for Transistor Sets 3/- P.P. 6d.

RADIO HEADPHONES

Balance armature type P.P. 2/6 **15/11**

DOUBLE THROAT MICROPHONE

Can be adapted for use with musical instruments. P.P. 6d. **4/11**

19 SET POWER PACK KIT. Only 39/6 P.P. 5/-
19 SET CONTROL BOX. Single type 2/11 each P.P. 1/6
Double type 3/11 P.P. 1/9

A NEW-PRACTICAL WAY of UNDERSTANDING

RADIO • TELEVISION • ELECTRONICS

Including: Transistors; VHF/FM; Hi-Fi Equipment; Computers; Servo-Mechs. Test Instruments; Photo-electrics; Nuclonics; etc.

Radiostructor—an organisation specialising in electronic training systems—offers a new self-instructional method using specially designed equipment on a “do-it-yourself” basis. You learn by building actual equipment with the big kits of components which we send you. You advance by simple steps, performing a whole series of interesting and instructive experiments—with no complicated mathematics! Instructional manuals employ the latest techniques for showing the full story of electronics in a practical and interesting way—in fact, you really have fun whilst learning!

RADIOSTRUCTOR

LEADS THE WORLD IN ELECTRONICS TRAINING

POST NOW

To RADIOSTRUCTOR (Dept. G149), READING, BERKS. Please send brochure, without obligation, to:

*Name

*Address

(We do not employ representatives) **12/63** *Block Caps Please

PRE-CHRISTMAS CLEARANCE

STOCKROOMS MUST BE CLEARED FOR CHRISTMAS STOCK

PRICES SLASHED

SALE!!!

Stock No. 101—Few Only MAINS BURGLAR ALARMS. With complete set of door and window microswitches and connecting wire, etc. Advertised at 7 gns. **OUR PRICE** to clear 39/6, plus 3/- P. & P.

Stock No. 105—39 ONLY PRECISION CAMERAS. Takes 127 film. To clear 8/6 each, plus 1/6 P. & P.

Stock No. 106—193 ONLY MINIATURE PLASTIC RADIO CABINETS, complete with Chrome carrying Handles, Dial and Tuning Knob. Size 5 3/4" x 3 1/2" x 1 1/2". Clearance price only 5/6, plus 1/- P. & P.

Stock No. 107—PRINTED CIRCUITS of 3 Transistor Reflex Radio made to fit above radio, 2/6, plus 1/6 P. & P.

Stock No. 169.
"VOLKSRADIO"
POCKET RADIO
ONLY **15/-**

Take-Over Bid makes this Fantastic Offer possible—the beautifully compact "5 Star Volkstradio" measuring 4 1/2" x 2 1/2" x 1 1/2" receives perfectly—in the bedroom, office, garden—over all medium waves (incl. Luxembourg). Under 1d. hour running cost. Anyone can assemble it in 1 or 2 hours, using our simple A B C plan. Complete set of parts. Only 15/-, plus 1/6 P. & P. C.O.D. extra. (Parts can be bought separately.)



Stock No. 125—BRAND NEW MAGNETIC DEAF AID TYPE EARPIECES, complete with Plug and Socket. 300 ohms. **OUR SPECIAL PRICE** 5/-, plus 6d. P. & P.

Stock No. 126—BRAND NEW CRYSTAL DEAF AID TYPE EARPIECES. **Our Price** 4/-, plus 6d. P. & P.

Stock No. 130.

SELL SAFETY TO THE MOTORIST

AUTOMATIC CIGARETTE LIGHTER

Instantly provides ready lit cigarette, without the driver taking his eyes from the road. Heavily chromium plated case holds 10. Easily and simply fitted to any car's dashboard. Works off 6 or 12 volts. Retail Price 44/9. **Special Clearance Offer**, only sold in minimum lots of 6. 10/6 each. Carriage free.



Stock No. 119—72 ONLY MINIATURE 6 TAG COILS covering Medium Wave and Long Wave with reaction winding. Price to clear 3/- each, plus 6d. P. & P.

Stock No. 120—SIMILAR TO ABOVE, but Medium Wave only 2/- each, plus 6d. P. & P.

Stock No. 143—265 ONLY! MINIATURE PRECISION "MINETTA" SPY CAMERAS complete with 6 rolls of film and real leather carrying case. Size 2 1/4" x 1 1/2" x 1 1/4". Price to clear 20/- each. Post Free.



Stock No. 144—BRAND NEW 2 1/2" MOVING COIL LOUDSPEAKERS. **SPECIAL PRICE** 9/6, plus 1/6 P. & P. 30 ohms.

Stock No. 151—BRAND NEW "PLESSEY" MOVING COIL SPEAKERS. 2 1/2". 60 ohms. Matches Transistor Direct—No O.P.T. needed. **Special price** 12/6, plus 1/6 P. & P.

Stock No. 152—BRAND NEW H.F. TRANSISTORS. (Equivalent to OCT1.) **OUR PRICE** 2/9, plus 3d. P. & P.

TERMS OF BUSINESS

C.O.D. 2/6 extra, regret No C.O.D. under £1. Add extra postage for overseas. Special prices for quantity and the Trade. All goods guaranteed. Components, technical books, Hi-Fi by Leak, Jason, Lorenz, Quad, etc. Send S.A.E. for quotation or with any enquiry.

Stock No. 162—BRAND NEW SUB-MINIATURE ELECTROLYTIC CONDENSERS. 100 MFD. 12V., 2/- each, plus 6d. P. & P.

Stock No. 165—SURPRISE PARCEL TYPE (a) Assorted components. Price 5/-, plus 1/6 P. & P.

Stock No. 166—SURPRISE PARCEL TYPE (b). Containing 3 times the above components. Price 12/6, plus 1/6 P. & P.

Stock No. 167—GIANT SURPRISE PARCEL TYPE (c). Price 15/-, plus 2/- P. & P.

Stock No. 170 TRANSISTOR POCKET RADIOS BULK PURCHASE ENABLES US TO MAKE THIS FANTASTIC OFFER AND WITH MONEY BACK GUARANTEE!!!

The "SAN REMO" . . . so tuned that it brings the voices of star entertainers and vocalists dramatically to life—in your home, office, etc. Only 4 1/2" x 2 1/2" x 1 1/4". Fits easily into your pocket or handbag. Works for months off 1/2 battery. Should last a lifetime. Anyone can assemble it in an hour or two with our easy plan. Complete set of parts including miniature speaker, carrying case—everything only 28/6, P. & P. 2/6. C.O.D. 2/6 extra. (Parts can be bought separately.) Limited period—so rush your order before it is too late. DEMONSTRATIONS DAILY.

ONLY 28/6

No More To Pay. Complete Set of Parts.

Stock No. 168—SPECIAL CLEARANCE OF FULLY GUARANTEED BRAND NEW "BENKSON" GOLD FRONT 6 TRANSISTOR SUPERHET RADIOS. Complete with real leather carrying case. Personal Earpiece, Battery. All in Beautiful Presentation Boxes. Only 75/-, plus 2/6 P. & P. 74 Only. Advertised at £6.6.0 recently. Last 74—No more available.

CONCORD ELECTRONICS (Dept. RC1), 210 Church Road, Hove, Sussex

PERSONAL CALLERS WELCOME: Open 8.30 a.m. until 1 p.m. & 2 p.m. until 5.30 p.m. Saturdays: 8.30 a.m. to 1 p.m. ★ Demonstrations Daily

SMALL ADVERTISEMENTS

Use this form for your small advertisement

To: The Advertisement Manager, Data Publications Ltd., 57 Maida Vale, London, W.9
Please insert the following advertisement in the issue of THE RADIO CONSTRUCTOR

16 words at 9d.
= 12/-

ALL WORDING
IN
BLOCK LETTERS
PLEASE

I enclose remittance of being payment at 9d. a word. MINIMUM 12/-.
Box Number, if required, 2/- extra.

NAME

ADDRESS

Copy to be received four weeks prior to publication. Published on the 1st of every month

SMALL ADVERTISEMENTS

continued from page 355

TRADE—continued

PROFESSIONAL HAMMER FINISH for your instrument cases, brackets, etc. A really beautiful effect, easily applied by brush. Air dries in 20 minutes. $\frac{1}{8}$ pint tin 2s. 11d., plus 4d. P. & P. Pewter, green or blue.—Finnigan Speciality Paints, 5 Stanley Square, Stalybridge, Cheshire.

FOR SALE. Government surplus radio and electronic gear. R220 receivers, power units, inp. units, meters, relays, etc. Send for free lists.—Slater, 34 Lifford Street, Sheffield 9, Yorkshire.

FIND TV SET TROUBLES IN MINUTES from that great book *The Principles of TV Receiver Servicing*, 10s. 6d., all book houses and radio wholesalers. If not in stock, from—Dept. D, Secretary, 32 Kidmore Road, Caversham, Reading, Berkshire.

JOIN THE INTERNATIONAL S.W. LEAGUE. Free Services to members including Q.S.L. Bureau. Amateur and Broadcast Translation. Technical and Identification Dept.—both Broadcast and Fixed Stations, DX Certificates, contests and activities for the SWL and transmitting members. Monthly magazine, *Monitor*, containing articles of general interest to Broadcast and Amateur SWLs, Transmitter Section and League affairs, etc. League supplies such as badges, headed notepaper and envelopes. QSL cards, etc., are available at reasonable cost. Send for League particulars. Membership including monthly magazine, etc., 21s. per annum.—Secretary, ISWL, 12 Gladwell Road, London, N.8.

THE INTERNATIONAL HAM HOP CLUB is a non-profit-making organisation open to RADIO AMATEURS AND SHORT WAVE LISTENERS. OBJECT: to improve international relationships through an organised system of hospitality. MEMBERS offer overnight hospitality to visiting members, subscription 10s. per annum. ASSOCIATE MEMBERS invite radio amateurs to visit their stations. Associate membership 5s. per annum. FAMILY EXCHANGE holidays arranged, also FRIENDSHIP LINKS between radio clubs. The Club's official journal is free to both Full and Associate Members.—Hon. Gen. Secretary: G. A. Partridge, G3CED, 17 Ethel Road, Broadstairs, Kent.

PRIVATE

FOR SALE. *Wireless World*, singly or bulk. Vol. LII, 1946, Nos. 6, 10 and 11. Vol. LVI, 1950, all except No. 6. Vol. LVII, 1951, all except Nos. 9, 11 and 12. Vol. LVIII, 1952, all except Nos. 4, 5, 6 and 12. Vol. 59, 1963, No. 12. Offers?—Box No. F186.

FOR SALE. Quantity of new accumulators. Varley type VPT 9/17. 2 volt, 11 amps. hrs. at 1 hr. rate. Willard Radio-20-2, 2 volt, 5s. each, plus carriage.—Box No. F187.

continued on page 359

SPEAKERS BY GOODMAN'S, ELAC, PLESSEY, etc.

4" square 12/-	P & P 1/6
5" round 12/-	1/6
7" x 4" elliptical 13/6	1/6
8" x 3" elliptical 16/6	2/-
10" x 6" elliptical 23/6	2/-

18G STEEL CASES

Finished in superior quality hammer grey with aluminium removable panel on face.

Sloping Front:		
4" x 4" x 4"	10/6	
8" x 5" x 5"	16/-	
12" x 6" x 6"	25/6	

Rectangular Small		
4" x 4" x 2½"	8/6	
6" x 4" x 3"	10/-	
8" x 6" x 3"	12/6	

Rectangular Standard		
10" x 7" x 7"	27/6	
12" x 7" x 7"	34/-	
14" x 7" x 7"	37/6	
14" x 8" x 9"	47/6	
16" x 8" x 9"	52/6	
16" x 8" x 11"	57/6	
19" x 8" x 11"	64/-	
19" x 10" x 11"	66/-	

Postage and Packing extra

OUR FAMOUS READIPACKS!

No. 1	100 resistors $\frac{1}{4}$ w. to 5w. 10 ohm to 50 meg.
No. 2	25 condensers 1pF to 1,000pF 5% to 20%
No. 3	20 condensers 1,000pF to 0.01 mfd
No. 4	12 condensers 0.01 mfd. to 0.1 mfd
No. 5	25 Hi-Stab resistors 1, 2 & 5% 10Ω-25 meg.
No. 6	10 w/w Resistors 6 ohm-82K ohm
No. 7	4 Carbon controls volume, tone, etc.
All at 8/6 each	
POST FREE!	

SWITCHES for MULLARD circuits to specification and "Mullard approved".

TR1	2V Pre-Amp	12/9
TR3	3V Pre-Amp	12/9
TR4	3V Pre-Amp Lo/Pass Fltr	10/9
TR5	3V Pre-Amp Hi-Pass Fltr	8/4
TR6	3V Tape Amp Rec/Play	16/6
TR7	3V Tape Amp Eqz	7/4
TR8	Tape Pre-Amp Rec/Play	16/6
TR9	Tape Pre-Amp Eqz	7/4
TR10	Stereo Pre-Amp Selector	18/6
TR11	Stereo Pre-Amp Ch/E	9/6
TR12	Stereo Pre-Amp Stereo-Mono	9/6
P & P 1/- per switch		

TELE-RADIO (1943) LTD
189 EDGWARE ROAD, LONDON, W2
PADdington 4455

OSMOR

PRICE LISTS & INFORMATION ON

Various Designs in

Practical | Radio | Wireless | R.S.G.B.
Wireless | Constructor | World | Bulletin

SEND 6d. POSTAGE FOR



CIRCUITS

OSMOR LTD

418 BRIGHTON ROAD
S. CROYDON SURREY
Telephone CRO 5148

REVISED EDITION- — — —NOW AVAILABLE

SHORT WAVE RECEIVERS FOR THE BEGINNER



SHORT WAVE RECEIVERS FOR THE BEGINNER

with Preface and Introduction by FRANK A. BALDWIN, A.M.I.P.R.E.

72 Pages

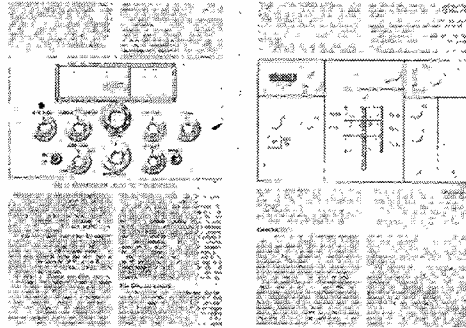

6s.

This book has been specially prepared for the beginner interested in short wave receiver construction and operation. **NOW FEATURES** the "NIGHTRIDER" 5/7 valve communications receiver. Altogether 8 versions of 4 basic receiver designs, 2 of these including step-by-step building instructions. *Contents also include:* Introduction to the Short Waves; Soldering Notes, etc.

Complementary to "THE RADIO AMATEUR OPERATOR'S HANDBOOK"

To Data Publications Ltd., 57 Maida Vale, London, W.9

Please supply.....copy(ies) of your latest publication "SHORT WAVE RECEIVERS FOR THE BEGINNER", DATA BOOK No. 14 at 6s. each, postage 5d.

NAME

ADDRESS.....

BLOCK LETTERS PLEASE

SHORT WAVE RECEIVERS FOR THE BEGINNER



SMALL ADVERTISEMENTS

continued from page 357

PRIVATE—continued

FOR SALE. Brand new computer panels with 8 OC76 transistors, numerous diodes, resistors and capacitors, fitted on 12 x 5in Paxolin board, 20s.—Clappison, 190 Victoria Avenue, Hull.

FOR SALE. Meters: 0–500mA, flush, round, 2½in diam. Ditto 0–100mA, 10s. each. Valves: 6B8, 6SK7, at 3s. 6AG5, 6AT6, 6J6, 1625, at 5s. 6AK6, 6BW6, DAF91, DK91, DL92, EB91, EF92, EL41, EL91, 12AT7, at 6s. EF40, 6AS7, 6BR7, KT66, at 10s. QVO4/7, 5B/254M at 15s.—Box No. F189.

FOR SALE. *Radio & TV Servicing*. 10 volumes in mint condition. Pre-1953–1962. Current price new: £15 15s. 0d. for last 6 volumes only. Best offer over £12.—Giffard, 49 Worcester Road, Sutton, Surrey.

WANTED. Newnes *Radio & TV Servicing*, 1959–60 models. State price and condition.—Vickers, Charlecote Park, Warwick.

FOR SALE. T1540 transmitter in travelling case. £12 or nearest offer.—D. Bootle, Hawksridge, Denham Aerodrome, Uxbridge, Middlesex. Telephone Denham 3120.

FOR SALE. R107 £14. R208 £7. W/S18 plus No. 5 power unit £5.—Portus, Belton, Nr. Grantham, Lincolnshire.

FOR SALE. Heathkit oscilloscope 0–12U. Good condition, very little used. £25. Buyer must collect.—Kempster, Pier View Hotel, Newtown, Berkeley, Gloucestershire.

FOR SALE. Over £30 magazines including *Wireless World*, *Radio Constructor*, *Practical Wireless*, *Practical Television*, etc., £2 10s. 0d. New a.m./f.m. tuning unit £2 10s. 0d. Radiola transistor radio £2 10s. 0d. Test meter, ohms, volts, milliamp ranges, £1 5s. 0d. Cossor oscilloscope £10. Reflectograph 500 professional tape recorder, four track heads, £50. Carriage and insurance extra.—Box No. F192.

PANL BLACK CRACKLE PAINT

Give your metalwork a really professional finish.
Easily applied by brush. Air drying.

Available by post from

THE BRUCE MILLER CO. LTD
249 COASTAL CHAMBERS
BUCKINGHAM PALACE ROAD SW1

4/- per ½ pint can which includes application instructions, postage and packing

LABORATORY ASSISTANTS

preferably with academic qualifications equivalent to O.N.C. (Elec.Eng.) are invited to apply to—

International Aeradio Limited

Good promotion prospects.
Superannuation.
Cheap holiday air travel.

Write to:

The Personnel Officer,
International Aeradio Limited,
Hayes Road, Southall, Middx.

CASTLE & CONTRAST RECORDS

- EFX-1 **ELECTRONIC MUSIC**
Two compositions "Cosmos" and "Vortex"—Electronic sound effects—space ships, etc.—15 separate tracks in all.
- MFX-3 **HORSES AND DOMESTIC ANIMALS**
Trotting—Jumping—Galloping—Cows—Cats and complete Fox Hunting calls and horns.
- HMX-1 **HAUNTED HOUSE AND MYSTERY**
Electronic Mystery Music (2)—Violent Storm (authentic)—Creaking—Clocks—Shriek—and electronic Ghost and Spook sounds, etc.
- COPYRIGHT FREE

SOUND EFFECTS

- ALSO MFX-1 14 different effects.
MFX-2 12 different effects.
AFX-1 15 different wild animals.
TFX-1 11 different railway trains.
(Send for leaflet—3d. stamp)

COLOUR GLOSSY SLEEVE gives full details of each separately tracked effect and timing.

Audio and Record Review: "These are truly Hi-Fi sound effects records."

Amateur Tape Recording: "Splendid records, full of useful sounds."

PRICE: 8s. each which includes P.T., postage and special packing.

SPECIAL OFFER: Complete set of seven records 50s. inc. P.T., postage and packing.

DIRECT MAILING from:

F. C. JUDD (Sound Recording) LTD.
174 Maybank Road, South Woodford, London, E.18

CHASSIS and CASES by



287/9 Edgware Road
London W2
TELEPHONE
PADDINGTON 5891/7595

BLANK CHASSIS—Same Day Service

Of over 20 different forms made up to YOUR SIZE.
Order EXACT SIZE you require to nearest 1/16th.
(Maximum length 35", depth 4".)
Specials dealt with promptly.

SEND FOR ILLUSTRATED LEAFLETS

or order straight away, working out total area of material required and referring to table below which is for four-sided chassis in 18 s.w.g. (for 16 s.w.g. add 1/16th).
48 sq. in. 4/- 176 sq. in. 8/- 304 sq. in. 12/-
80 sq. in. 5/- 208 sq. in. 9/- 336 sq. in. 13/-
112 sq. in. 6/- 240 sq. in. 10/- 368 sq. in. 14/-
144 sq. in. 7/- 272 sq. in. 11/- and pro rata
P. & P. 2/6 P. & P. 2/9 P. & P. 3/-

Discounts for quantities. Finishes arranged for quantities of 25 or over.

FLANGES (1/2" or 3/4"), 6d. per bend.
STRENGTHENED CORNERS, 1/- each corner.
PANELS

Any size up to 3ft at 4/6 sq. ft. 18 s.w.g. (16 s.w.g. 5/3).
Plus postage and packing (orders over £2 Post Free).

CASES

ALUMINIUM, SILVER HAMMERED FINISH			
Type	Size	Type	Price
U	4 x 4 x 4"	Y	8 x 6 x 6" 25/-
U	5 1/2 x 4 1/2 x 4 1/2"	Y	12 x 7 x 7" 39/-
U	8 x 6 x 6"	Y	13 x 7 x 9" 44/-
U	15 x 9 x 9"	Y	15 x 9 x 7" 46/-
W	8 x 6 x 6"	Z	17 x 10 x 9" 63/-
W	12 x 7 x 7"	Z	19 x 10 x 8 1/2" 67/6
W	15 x 9 x 8"		* Height

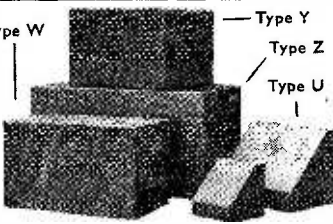

Type Z has removable back and front panels.
Type Y all-screwed construction.

The thrills of VHF Amateur Radio can now be yours for as low as 39/6!—complete kit (by post 2/6 extra)—tuneable range, 70-150 Mc/s. Write today for interesting literature, s.a.e. please. If a newcomer to Short-Wave radio, ask for a free copy of world-famous "Globe-King" S.W. kits and other receivers, etc.—stamp for post please, not s.a.e.

Johnsons (Radio) St. Martin's Gate Worcester

BRASS · COPPER · DURAL · ALUMINIUM · BRONZE · STAINLESS STEEL

ROD, BAR, SHEET, TUBE, STRIP, WIRE. 3,000 STANDARD STOCK SIZES
No Quantity too small List on application

H. ROLLET & CO LTD
HOWIE ST. LONDON SW11 BATTERSEA 7872
Also at Liverpool, Birmingham, Manchester, Leeds, Glasgow



ELECTRONIC ORGAN KIT

For home entertainment, or musical group. Transistor, battery operated, self-contained loudspeaker, two octave. No musical knowledge needed to play. Can be connected to power amplifier if required for a band, etc. Complete Kit of Parts 79/6 Plus 2/- and instructions p. & p.
Size 14 in. long x 6 in. deep x 3 in. high.
Tremolo parts can be supplied.

M.D.C. (Sonics) · 43 Rushall Manor Road · Walsall · Staffs

Quality Components FOR CONSTRUCTORS

capacitors, resistors, coils, valves, transistors, controls, chassis, transformers, speakers, pick-ups, cartridges, stylii, and all types of components in stock.

CATALOGUE AVAILABLE ON REQUEST

J. T. FILMER 82 DARTFORD ROAD
DARTFORD KENT
Telephone Dartford 24057

What they are saying about the KING TELEBOOSTER

"astounded with performance" . . . "working very well, buying another" . . . "good gain in extremely difficult fringe area" . . . "can thoroughly recommend" . . . "very good" . . . "recently bought two . . . every satisfaction".

The Telebooster is a low-noise, two-channel pre-amp, self-contained with battery in 3 1/2 x 3 1/2 x 2 in plastic case. Gives at least 5 times boost on B.B.C. and I.T.A. simultaneously (two amps in one!). Pulls good pictures out of grain, permits indoor aerials, DX TV and works up to 6 sets from one aerial. Just plug between aerial and set and switch on!

NOW also KING FM-BOOSTER. Same price and style but 6 times boost on any group of 3 or 4 FM stations.

Each booster only 75/6 with PP3 battery. (P. & P. 2/6 extra). State B.B.C. and I.T.A. channels required.

From **GORDON J. KING LIMITED**
6 NEW ROAD, BRIGHAM, DEVON

E. R. NICHOLLS 46 LOWFIELD ROAD SHAW HEATH STOCKPORT

BUMPER PARCEL

- | | |
|--------------------------|--|
| 100 Assorted Resistors | 1 Small Chassis containing 60 components |
| 50 Assorted Condensers | |
| 1 5in 3 ohm Elac Speaker | 2 Westectors |
| 1 Isolating Transformer | 2 Thermistors |
| 4 Terminal Blocks | 100 Cartridge Fuses |
| 2 Rotary Toggle Switches | |
- ALL FOR 20/-, Post free in U.K.

20ft Steel Telescopic Mast, 50/- High Stab Resistors 6d. ea.
List now ready for Paper Block Condensers, Valves, Oscillators, Test Sets. S.A.E. please.

Mail Order to
33/35 CARRINGTON FIELD STREET STOCKPORT CHESHIRE

THE RADIO CONSTRUCTOR

NOW AVAILABLE

VOLUME 16 AUGUST 1962 to JULY 1963
PRICE £1. 10. 0. Postage 2s. 9d.

Where all issues are returned: Price £1. Postage 2s. 9d.

ALSO AVAILABLE

Volume 13, August 1959 to July 1960 £1. 5. 0. postage 2s. 3d.
Volume 14, August 1960 to July 1961 £1. 5. 0. postage 2s. 3d.

We regret Volume 15 is now sold out

DATA PUBLICATIONS LTD 57 MAIDA VALE LONDON W9

BOUND VOLUMES

TRANSISTORS, CRYSTALS, VALVES, COMPONENTS & EQUIPMENT

FOR THE AMATEUR & PROFESSIONAL—TRADE SUPPLIED—QUOTATIONS BY RETURN
ALL LINES PREVIOUSLY ADVERTISED STILL AVAILABLE FROM STOCK

"CAPRI" POCKET RADIO 6-TRANSISTOR SUPERHET



Size only 4 1/4" x 2 3/4" x 1 1/4"
REALLY POCKET SIZE!

The most compact 6-transistor and diode radio with speaker available to the home constructor. Features the latest in miniature components and circuitry. Supplied with Mullard transistors and two-tone moulded cabinets in red-white or blue-white with gold fittings. All components are supplied in packets and clearly identified. A printed circuit is used with fully illustrated building instructions. Push-pull output coupled with a sensitive and selective circuit make the "CAPRI" hard to beat. Fitted Earphone/Record Socket. Full tuning on medium waves with long wave Light. All parts sold separately.

TOTAL COST OF ALL PARTS 79/6 P.P. 2/-.
(Battery 2/6 extra. Earphone 6/6 extra.)
Illustrated leaflet on request.



MULTI-METERS

Multi-range test meters featuring easy to read scales and provided with full operating instructions, lead and batteries. Suitable for amateurs, designers, repair shops, all domestic uses. Full details and specifications in our catalogue.

★ PT34, 1kΩ/volt	£2. 5.0
★ M1, 2kΩ/volt	£2. 9.6
★ THL33, 2kΩ/volt (illus.) ...	£3.15.0
★ EP10K, 10kΩ/volt	£4. 9.6
★ ITI-2, 20kΩ/volt	£5. 5.0
★ TP55, 20kΩ/volt	£5.19.6
★ EP30K, 30kΩ/volt	£6.19.6
★ 500, 30kΩ/volt	£8.19.6
★ EP50K, 50kΩ/volt	£9.19.6

Crystal Contact Microphone, 12/6. P.P. 9d.
2K, 1/2-track Tape Head, 15/-, P.P. 9d.
Telephone Recording Attachment, 12/6.
P.P. 9d.
4-channel Transistor Mixer Unit, 59/6.
Tape Jack Radio Tuner, 29/-, P.P. 1/-.

RUN YOUR RADIO OR AMPLIFIER FROM MAINS BATTERY ELIMINATORS AND CHARGERS

1. For PP3 or equivalent 9 volt Pocket Radio Battery, 18/6. P.P. 1/-.
2. For PP4, PP7, PP9, 9 volt Portable Radio and Equipment. Supplies up to 300mA, 49/6. P.P. 2/-.
3. De Luxe version of No. 1, also charges PP3 type batteries, 24/-, P.P. 1/-.

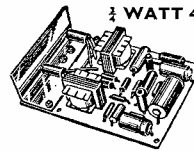

1/2 WATT 4 TRANSISTOR AMPLIFIER

- ★ Improved Version.
- 1 1/2 watt peak output.
- ± 3dB 70 c/s to 12 kc/s.
- Output to 3 ohm speaker 9 volt operated.

Built and Tested 59/6 OR 52/6

P.P. 1/6 P.P. 1/6

Details on request.

TAPE RECORDERS

- ★ COLLARO STUDIO 2-TRACK DECK, £10.19.6. P. & P. 5/-.
 - ★ 4-TRACK DECK, £13.19.6 P. & P. 5/-.
 - ★ CABINET with SPEAKER for above, 5 gns. P. & P. 2/-.
 - ★ RECORD/PLAY AMPLIFIER KITS, 2 track, 11 gns. 4 track, 12 gns.
- Leaflets on Request.

MAIN DECKS

- ★ GARRARD AUTOSLIM. 4 speed changer, £6.10.0. P. & P. 3/6.
- ★ PLUG IN HEAD VERSION, £7.10.0. P. & P. 3/6.
- ★ GARRARD AT6 STEREO £11.19.6. P. & P. 3/6.
- ★ B.S.R. UA14 4 speeds, £5.19.6. P. & P. 3/-.

BATTERY DECKS

- ★ STAR 45 r.p.m., 39/6. P. & P. 2/6.
 - ★ GARRARD 45 r.p.m., 35/-, P. & P. 2/-.
 - ★ STAR 45 and 33 r.p.m., 92/6.
 - ★ B.S.R. 4 speed, 5 gns. P. & P. 2/6.
- All decks fitted Crystal pick-ups.

CRYSTAL MICROPHONES

(See Catalogue for details)

Acos 39-1 Stick Microphone ...	32/6
Acos 40 Desk Microphone ...	15/-
Acos 45 Hand Microphone ...	25/-
Acos 60 Stick Microphone ...	27/6
Lapel/Hand Microphone ...	12/6
MC24 Stick Microphone ...	25/-
100C Stick with Stand ...	39/6
BM3 Stick with Stand ...	52/6
Lapel/Hand Magnetic ...	12/6

Post and Packing 1/6 any type.

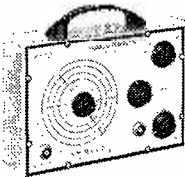

★ **NOMBREX ALL TRANSISTOR SIGNAL GENERATOR.** 150 kc/s to 350 Mc/s. AF, RF Mod., etc., £7.18.6, with leads, batt., etc.

★ **NOMBREX TRANSISTORISED RESISTANCE CAPACITANCE BRIDGE.** 1pF to 100 mfd., 1 ohm to 100 meg., leakage test, visual null indicator, £7.2.3, with batt.

★ **NOMBREX AUDIO GENERATOR.** 10 to 100,000 c/s. Sine/square, £15.2.3, with battery.

★ **NOMBREX TRANSISTOR POWER SUPPLY UNIT.** 1 to 15 volts D.C. up to 0.1 amp. 230/250V, A.C. mains, £5.17.6.

Post and Packing 2/6 any type.

★ **DETAILED LEAFLETS ON REQUEST ★**

MONO/STEREO AMPLIFIERS



Complete with full function pre-amplifiers and controls.

★ SA80 4+4 watts ...	£9.10.0
★ SA150 7+7 watts ...	£16.10.0
★ SA300 15+15 watts ...	£32.10.0

Each amplifier completely self-contained and designed for Mono and Stereo output. Supplied complete with full manual. Leaflets on any type on request.

HI-FI SPEAKERS

12" 15 ohms, 12,000 G. ...	35/-
8", 15/16 ohm (8A7) ...	78/6
12", 15/16 ohm (CR30AE) ...	10 gns

BRAND NEW—GUARANTEED

★ **TRANSISTOR POCKET RADIOS** Ready to use complete with Battery, Leather Case, Earphone.

6-Transistor Zephyr	79/6, P. & P. 2/-
6-Transistor De Luxe	85/-, P. & P. 2/-
7-Transistor Zephyr	89/6, P. & P. 2/-
7-Transistor M/L/SVY—3 waveband,	£13.19.6, P. & P. 5/-

HENRY'S RADIO LTD

PADDINGTON 1008/9
303 EDGWARE RD., LONDON W2
Open Monday to Sat. 9-6, Thurs. 1 o'clock

PLEASE TURN TO BACK PAGE

SUBSTITUTION BOXES

- ★ Capacitor Box. Provides 9 standard values from 0.001 to 0.22 mfd. at 600 volt working. 29/6.
 - ★ Resistor Box. Provides 24 standard values at 1 watt. 15 ohms to 10 meg., 37/6.
- Each box fully calibrated with insulated leads. Invaluable for service and design.

100 Kc/s QUARTZ CRYSTALS

2 Pin: OCTAL or 3 Pin 15/- ea.	
500 kc/s 2 Pin ...	15/-
455 kc/s (AR88) ...	12/6
5,000 kc/s 2 Pin ...	10/-
10 Mc/s 2 Pin ...	15/-
27.255 Mc/s ...	15/-
HC6U 18 Mc/s to 46 Mc/s 7/6	
80 frequencies 0.005% Acc.	

FIELD STRENGTH METER

Measures transmitter carrier waves from 1 Mc/s to 200 Mc/s in 5 switched fully adjustable ranges. Contains 200µA meter for carrier level and earphone for modulation. Requires no connection to transmitter. Self-contained, ready for use, 69/6, post free.

DEAC Rechargeable Batteries

- (a) 18V. 100mA/H 4" x 1" diam. Brand new, sleeved, 30/-
 - (b) As above but 150mA/H, 95/-
- Both types easily split into any multiple of 1.2 volt. Brand new

7-TRANSISTOR RECORD/PLAYER /RADIOGRAM AMPLIFIER

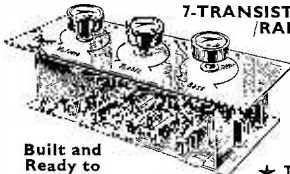

Built and Ready to Use

£5.19.6

P.P. 2/- (Complete with full descriptive Booklet)

Call for demonstration.

- ★ 4 watt peak output.
- ★ Full Treble and Bass boost and cut.
- ★ 40 c/s to 20 kc/s ± 3dB.
- ★ Inputs for Pick-ups, Radio Tuners, Microphone, Mixers, etc.

★ **TWO VERSIONS AVAILABLE**
12/18 volt for 15 ohm speakers (mains unit now reduced to 60/- extra).
9/12 volt for 3 ohm speakers (mains unit 49/6 extra)
★ Size only 6" x 2 1/4" x 2".
Ideal for mains or battery, portable or domestic record player, grams, etc.
★ Booklet Free on Request ★

We can supply from stock most of the components and items specified on circuits published in this and other magazines and radio books. Let us quote for your circuit.

HENRY'S RADIO LTD
303 EDGWARE ROAD LONDON W2
PADdington 1008/9
Open Monday to Sat. 9-6. Thurs. 1 o'clock

LATEST CATALOGUE
68 PAGES, 10" x 7½"
Fully detailed and illustrated 2/- post free



**"MINI-GRAM"
TRANSISTOR PORTABLE
RECORD PLAYER**

- ★ Ready Built 4-transistor 1 watt amplifier with elliptical speaker and volume control. 35/- P.P. 2/-.
- ★ 9 volt 45 r.p.m. turntable with Crystal pick-up. 39/6 P.P. 2/6.
- ★ Two-tone moulded case with handle, 5/- P.P. 1/-

Sold as three pre-built units with less than 30 minutes inter-connection work. Originally sold at more than double the price. A superb record player, fully portable—the ideal gift for teenager or adult.

OR TOTAL COST **79/6** P.P. 5/-

(Battery 3/9 extra)

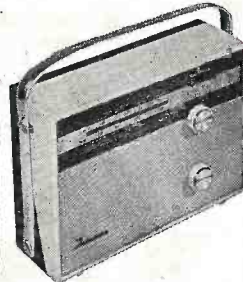

**'THE CONTESSA'
★ COMBINED PORTABLE AND
CAR RADIO ★**

AMAZING SENSITIVITY AND SELECTIVITY ON MEDIUM AND LONG WAVEBANDS

- ★ The easiest Superhet Radio to build on the market. Features clearly-marked printed circuit and packaged components with full illustrated building instructions. Full tuning of medium and long wave bands with unbeatable sensitivity and selectivity. Excellent tone and volume with over 600mW push-pull output.
- ★ Clearly marked horizontal station dial with slow motion tuning. Two colour Blue or Beige cabinets with Gold handles, grilles and fittings. Size 10½" x 7½" x 3½", includes car aerial socket, recording sockets.
- ★ 6 Mullard Transistors and 2 Diodes

TOTAL COST OF ALL PARTS **£9.19.6** P.P. 3/6

All parts sold separately — Guaranteed the Best Obtainable
★ Attractive Appearance — Quality Performance ★
UNBEATABLE FOR QUALITY AND VALUE

Fully Detailed and Illustrated Leaflet on request

**10 WATT TRANSISTOR
HI-FI AMPLIFIER AND PREAMPLIFIER**

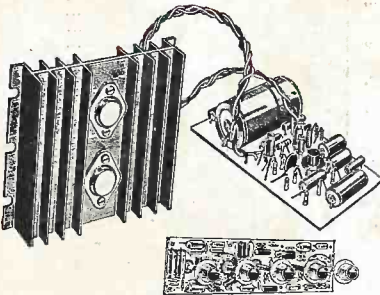

- ★ AVAILABLE IN KIT FORM OR PREBUILT PANELS
- ★ LOW NOISE
- ★ LOW POWER REQUIREMENTS
- ★ MONO OR STEREO

Circuits and details FREE on Request

PERFORMANCE EQUIVALENT TO VALVE AMPLIFIERS OF FOUR TIMES THE PRICE AND MANY TIMES THE SIZE

- ★ Power output 10 watts at 400 c/s. Second harmonic distortion 0.1%. Total harmonic distortion 0.25% at 10 watts. Signal to noise ratio at 10 watts 70 dB. Overall response within 3 dB 40 c/s to 20 kc/s.
- ★ 6-Transistor 10 watt power amplifier. 0.25 ohm output impedance for 3 ohms. 24 volt supply, 300mA average for 10 watts. 100mV into 33 k.ohm sensitivity.
Built **£5.19.6** P.P. 2/6 or Kit **£5.15.6** P.P. 2/6 (Mains Unit **£3.9.6** P.P. 2/6)
- ★ As above but 10 watts for 15 ohms speakers. 40 volt supply, 150mA average for 10 watts.
Built **£6.5.0** P.P. 2/9 or Kit **£6** P.P. 2/6 (Mains Unit **£3.9.6** P.P. 2/6)
- ★ Full function pre-amplifier on printed circuit. Size 9" x 2½". Features 6 position input selector for microphones, tuners, tape, pick-ups—treble and bass controls + 12dB at 50 c/s and 12 kc/s—14dB at 50 c/s and 12 kc/s. Four-position filter and volume controls. 1.5mV input sensitivity. ● Front Panel 8/6 extra ●
Built **£5.10.0** P.P. 2/- or Kit **£4.19.6** P.P. 2/-

★ CALL FOR DEMONSTRATION—ANY TIME ★

FM TUNER First Again!

SEE PAGE 343 THIS ISSUE

- ★ 5-Transistor
- ★ 4 Diodes
- ★ Full coverage 87 to 105 Mc/s
- ★ AFC and AVC

Printed circuit design of high sensitivity and quality. Output for valve or transistor amplifiers. Size 3½ x 2½ x 4". Simplified building instructions. All parts sold separately.

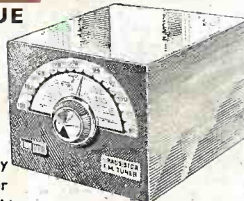

TOTAL COST **£8.19.6** P.P. 2/6

TO BUILD YOURSELF

PLEASE TURN TO NEXT PAGE	★ Miniranger	£2.9.6 P.P. 1/6
	★ Quintet M/LW	£3.19.6 P.P. 2/-
	★ Repanco DC/AC Inverter	£3.2.6 P.P. 2/6
	★ Sinclair Slimline	£2.9.6 P.P. 1/6
	★ PW-6 Pocket Superhet	£7.19.6 P.P. 2/-
	★ PW Celeste Portable	£9.15.0
	★ PW Spinette Record Player	£10.19.6
All TSL, Bernards, Repanco, Sinclair, Osmor, Ardenne, etc., components and books in stock. Quotations by return.		

BOAC VHF Pocket Receivers

- ★ Features 5 transistors (V6/8R—OC44) 2-OA91 diodes VHF detector, OA10 rectifier.
- ★ 1K ohm Stethoscope headset.
- ★ 3.9 volt 450mA/H rechargeable deac cells.
- ★ Moulded case with aerial/strap.
- ★ Full circuit and details.
- ★ Deac separately 12/6, P.P. 1/6.
- ★ Headset separately 15/-, P.P. 1/-.
- ★ Unit without above cell and phone 12/6, P.P. 1/6.

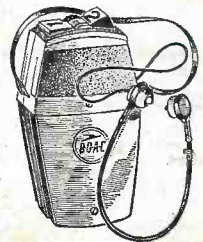

★ Complete with circuit, **35/-** P.P. 2/-.

Ideal for experimental receivers, personnel locators, etc.

4-WAVEBAND COMMUNICATIONS RECEIVER RX60 or SR40

550 kc/s—30 mc/s.—BFO—AVC—'S' meter—noise limiter—Bandspread —Telescopic aerial, etc. Brand new. Detailed leaflet on request.

- ★ De Luxe version, 9 valve Superhet, 2 RF Stages, etc.
- Leaflets on request ● **£42.0.0** P.P. 10/6.

Published in Great Britain by the Proprietors and Publishers Data Publications Ltd. 57 Maida Vale London W9

Printed by A. Quick & Co. (Printers) Ltd. Oxford Road Clacton-on-Sea England

Obtainable abroad through the following Collets Subscription Service Continental Publishers & Distributors Ltd. William Dawson & Sons Ltd. Australia and New Zealand Gordon & Gotch Ltd. Electronics Publications (Australia) South Africa Central News Agency Holland "Radio Electronica"

THE **Radio Constructor**

RADIO
TELEVISION
AUDIO
ELECTRONICS

VOLUME 17 NUMBER 5
A DATA PUBLICATION
PRICE TWO SHILLINGS

December 1963

COMPACT
Constructor's
TUNER

For use with a
Tape Recorder or Amplifier

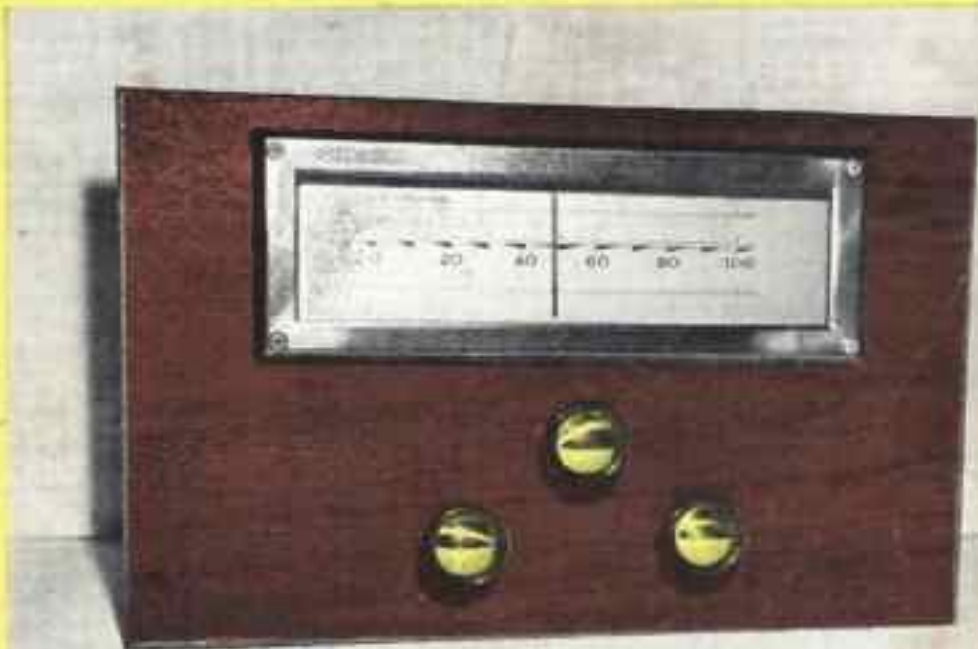

3+1 T.R.F.
Receiver

• Electronic
Rev. Counter

• 2W - 9V Transistor
Amplifier